

See discussions, stats, and author profiles for this publication at: <http://www.researchgate.net/publication/270899215>

A reduced observer design for a freezing process in plate freezers

CONFERENCE PAPER · JANUARY 2015

DOWNLOADS

28

VIEWS

266

2 AUTHORS:

 [Christoph Josef Backi](#)
Norwegian University of Science and Technology
10 PUBLICATIONS 7 CITATIONS
[SEE PROFILE](#)

 [Jan Tommy Gravdahl](#)
Norwegian University of Science and Technology
187 PUBLICATIONS 1,118 CITATIONS
[SEE PROFILE](#)



Christoph Josef Backi, Jan Tommy Gravdahl

Dept. of Eng. Cybernetics, Norwegian University of Science and Technology, N-7491 Trondheim, Norway
christoph.backi@itk.ntnu.no jan.tommy.gravdahl@itk.ntnu.no



INTRODUCTION

The process of freezing fish to a block in a vertical plate freezer (Figure 1) is studied. The aim is to monitor freezing time, which denotes the time it takes to freeze the center of the block to a specific temperature.

A pump forces the ammonia through the plate freezer, in which it partly vaporizes due to the heat taken off the fish block. The amount of heat added to the ammonia is removed in a compression/condensation/expansion - process.

Therefore the overall process (Figure 2) consists of two loops, an inner *evaporation loop* and an outer *regeneration loop*.



FIGURE 1: Vertical plate freezer

This work presents an observer design to estimate the non-measurable inner-domain temperatures inside a fish block.

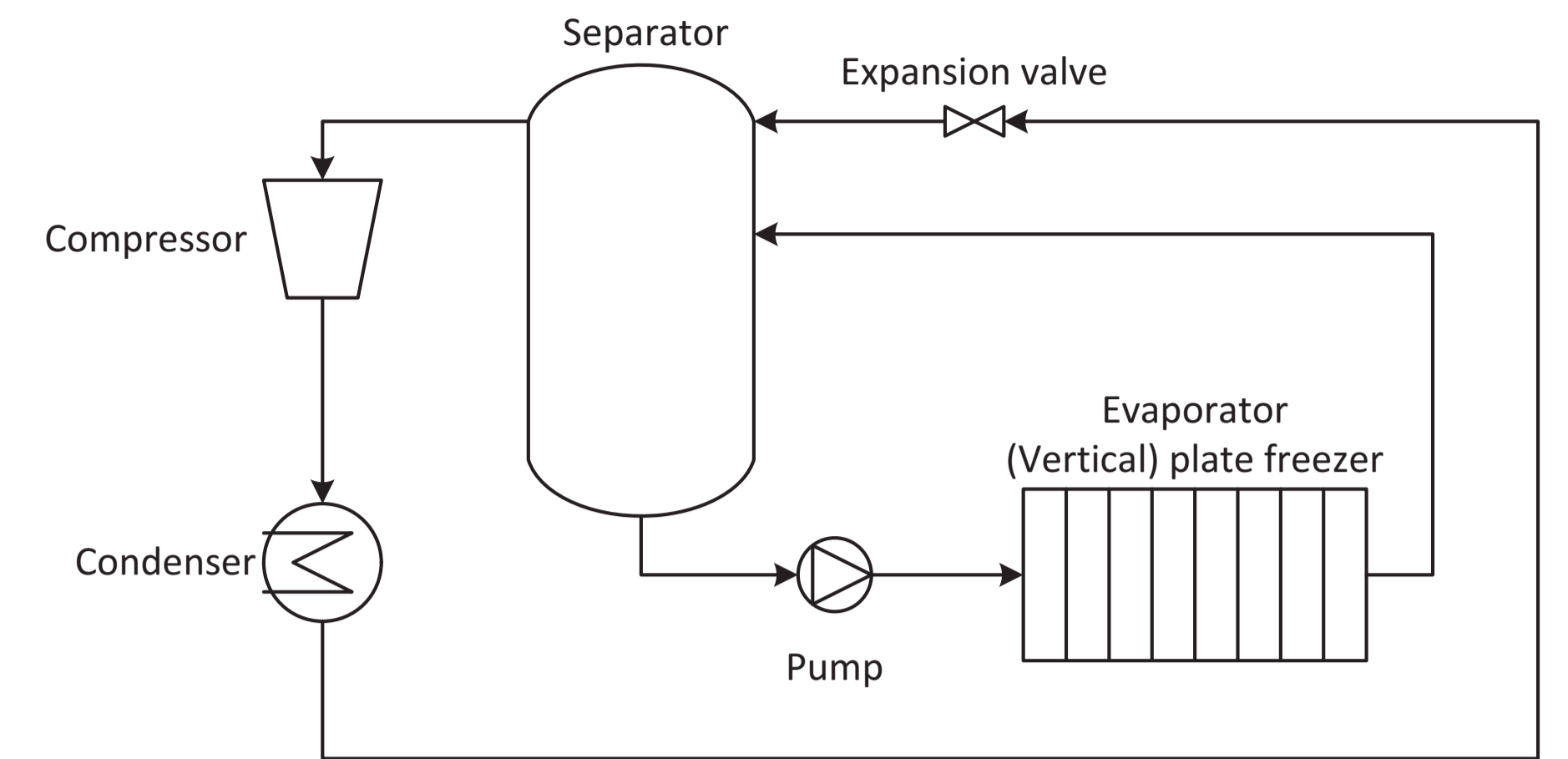

FIGURE 2: The overall process with inner and outer loop

MODEL

The temperature dynamics are modeled by a nonlinear heat equation in 2 spatial dimensions x and y ([4])

$$\rho(T)c(T)T_t(t,x,y) = [\lambda(T)T_x(t,x,y)]_x + [\lambda(T)T_y(t,x,y)]_y$$

$$\Rightarrow T_t(t,x,y) = \kappa(T) [T_x^2(t,x,y) + T_y^2(t,x,y)] + k(T) [T_{xx}(t,x,y) + T_{yy}(t,x,y)] \quad (1)$$

$$\text{with } \kappa(T) = \frac{\lambda_T(T)}{\rho(T)c(T)} \text{ and } k(T) = \frac{\lambda(T)}{\rho(T)c(T)},$$

where $\rho(T) = \rho = \text{const.}$ denotes density, $c(T)$ specific heat capacity and $\lambda(T)$ thermal conductivity.

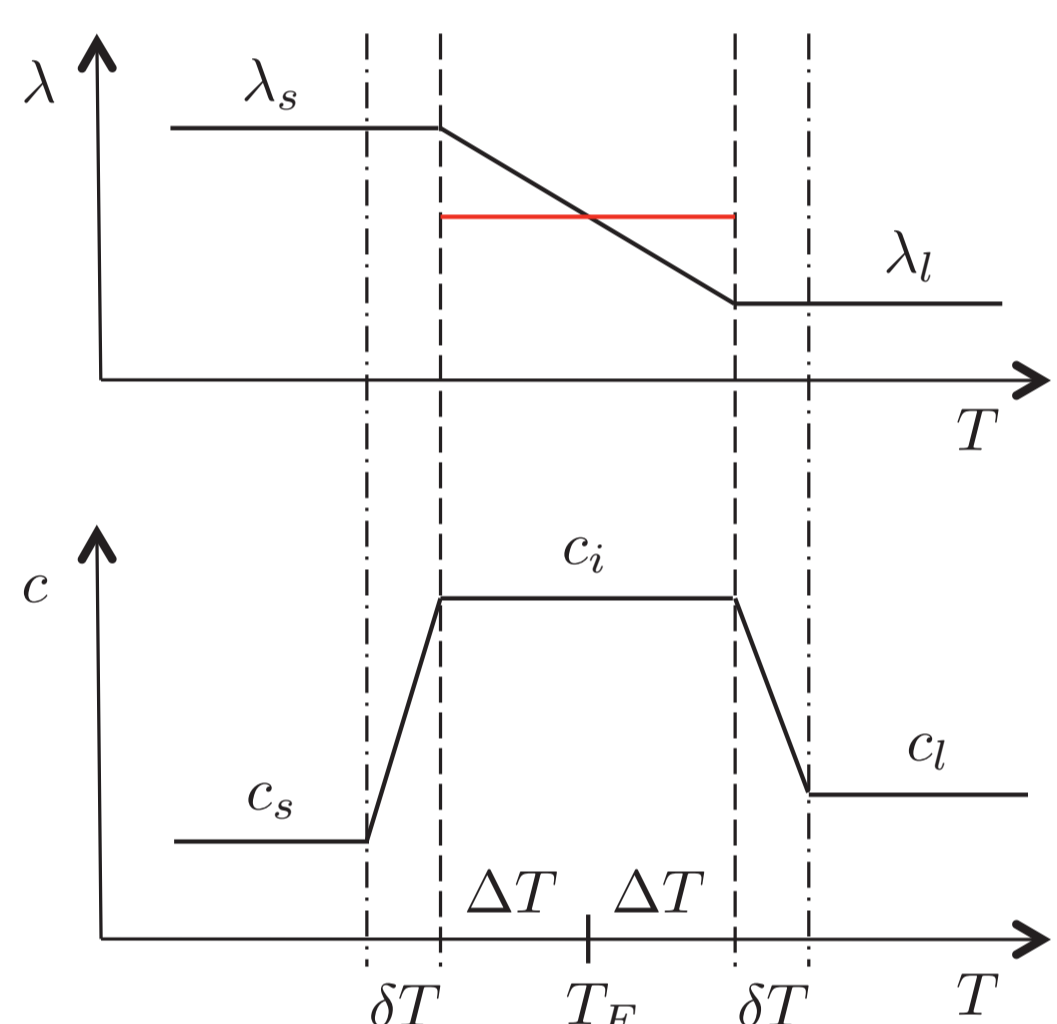

FIGURE 3: Parameters

Thermal arrest caused by latent heat of fusion is modeled by using the *apparent heat capacity method* (see [1] and [3])

OBSERVER

As in [2], we choose an *early lumping* approach, meaning spatial discretization before designing the observer. The block has length L and height H . Center and forward difference approaches are used resulting in $N \times M$ ODEs (see Figure 4). Measurable states are shown in yellow, non-measurable inner-domain temperatures in blue.

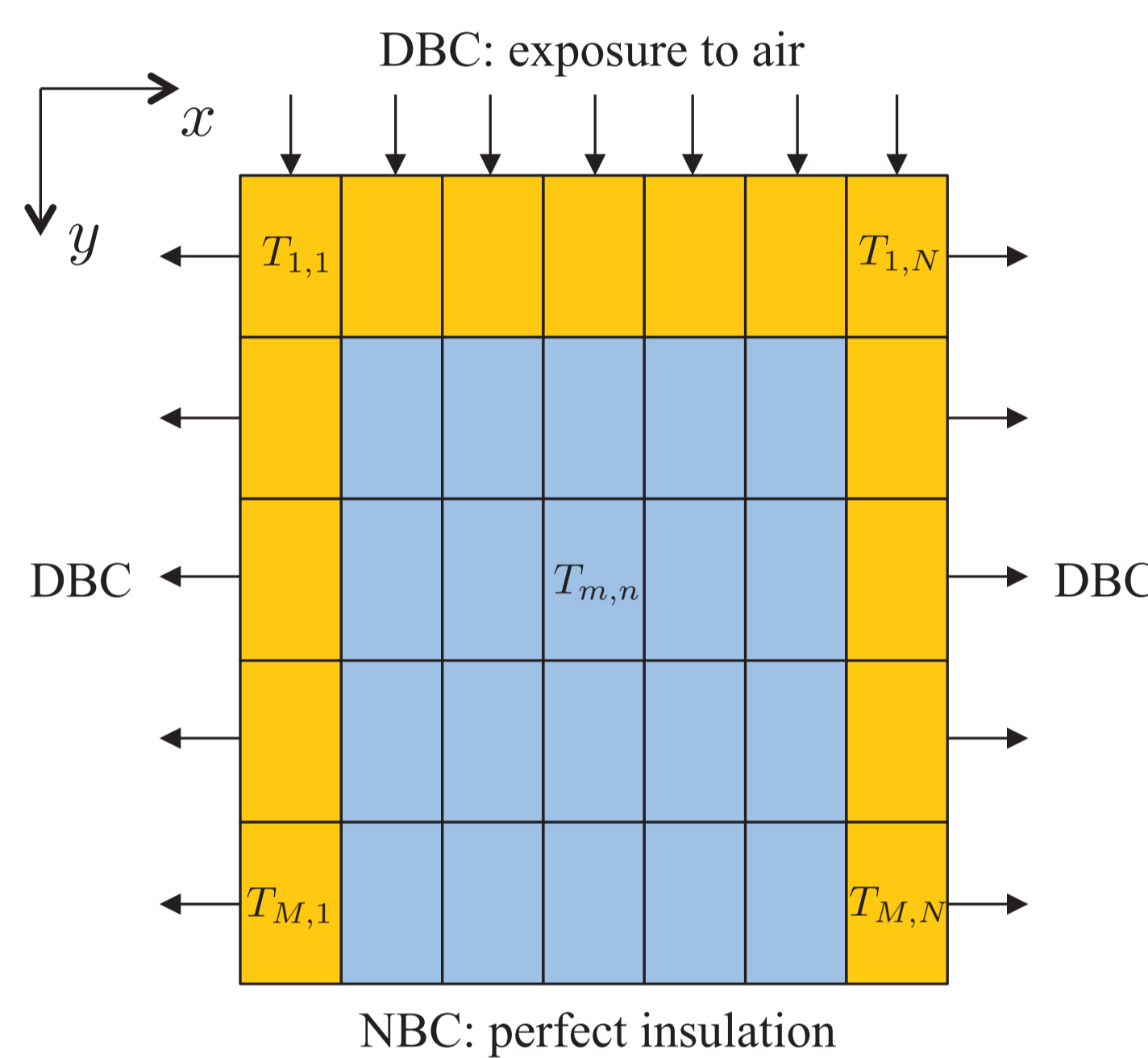

FIGURE 4: Discretization scheme

The Dirichlet boundary conditions (DBC) at $x = 0$ and $x = L$ are defined by $T_{Ammonia}$, the DBC at $y = 0$ is set by T_{Air} and the Neumann boundary condition (NBC) at $y = H$ denotes perfect insulation.

The observer is based upon an Extended Kalman Filter (EKF). The design schematic is shown in Figure 5.

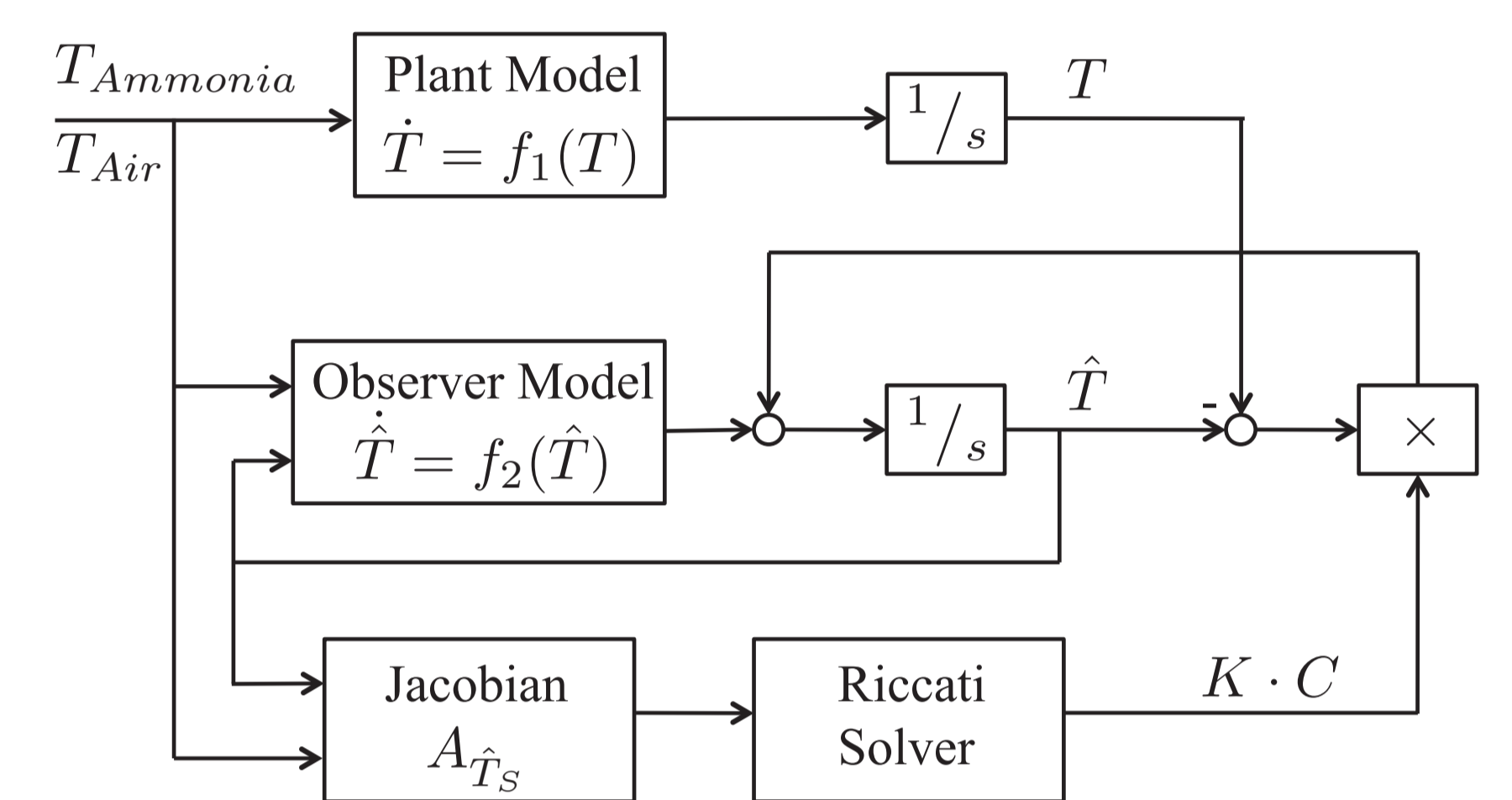

FIGURE 5: Observer schematic

The plant's dynamics f_1 are based upon the spatially discretized equation (1), whereas the EKF's dynamics f_2 ground on a reduced, spatially discretized version of (1),

$$\hat{T}_t(t,x,y) = k(\hat{T}) [\hat{T}_{xx}(t,x,y) + \hat{T}_{yy}(t,x,y)] + KC(\hat{T} - T).$$

The reason for the difference between f_1 and f_2 lies in the definitions of the parameter functions for the plant and the observer, respectively. This can be seen in Figure 3, where the constant red line visualizes $\lambda(T)$ in the region $T_F \pm \Delta T$ as chosen for the observer. The Jacobian $A_{\hat{T}_s}$ is solely used to solve the Riccati differential equation and thus to compute the observer feedback matrix K .

RESULTS

The following settings were used for the simulations:

- $N = 9, M = 5$ and simulation parameters as used in [1]
- The following relations hold for the parameters: $k_{EKF} = 2k_{Plant}$, $\kappa_{EKF} = 2\kappa_{Plant}$ and $\Delta T_{EKF} = 2\Delta T_{Plant}$
- Initial conditions are evenly distributed and diverge by 3 K

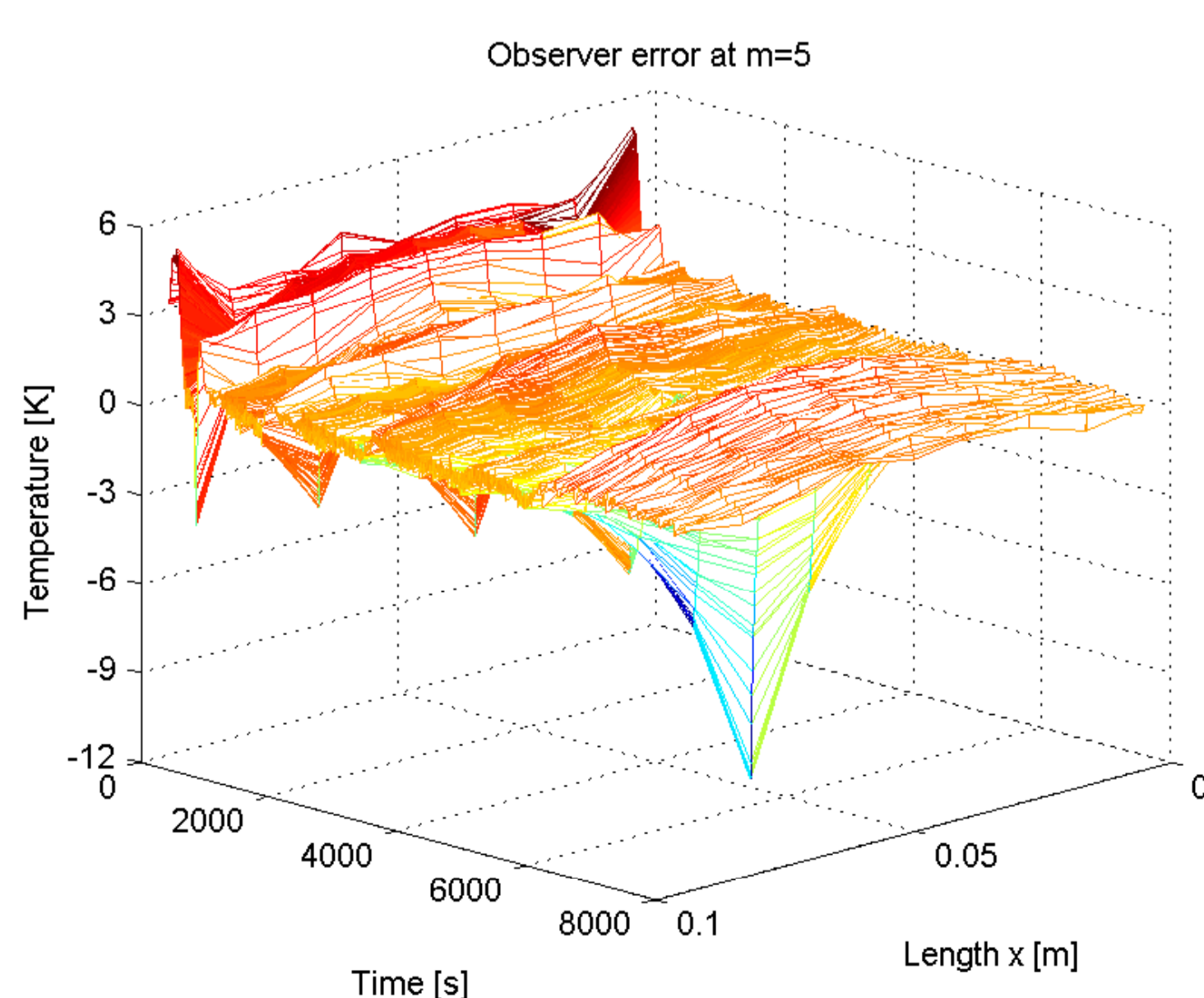
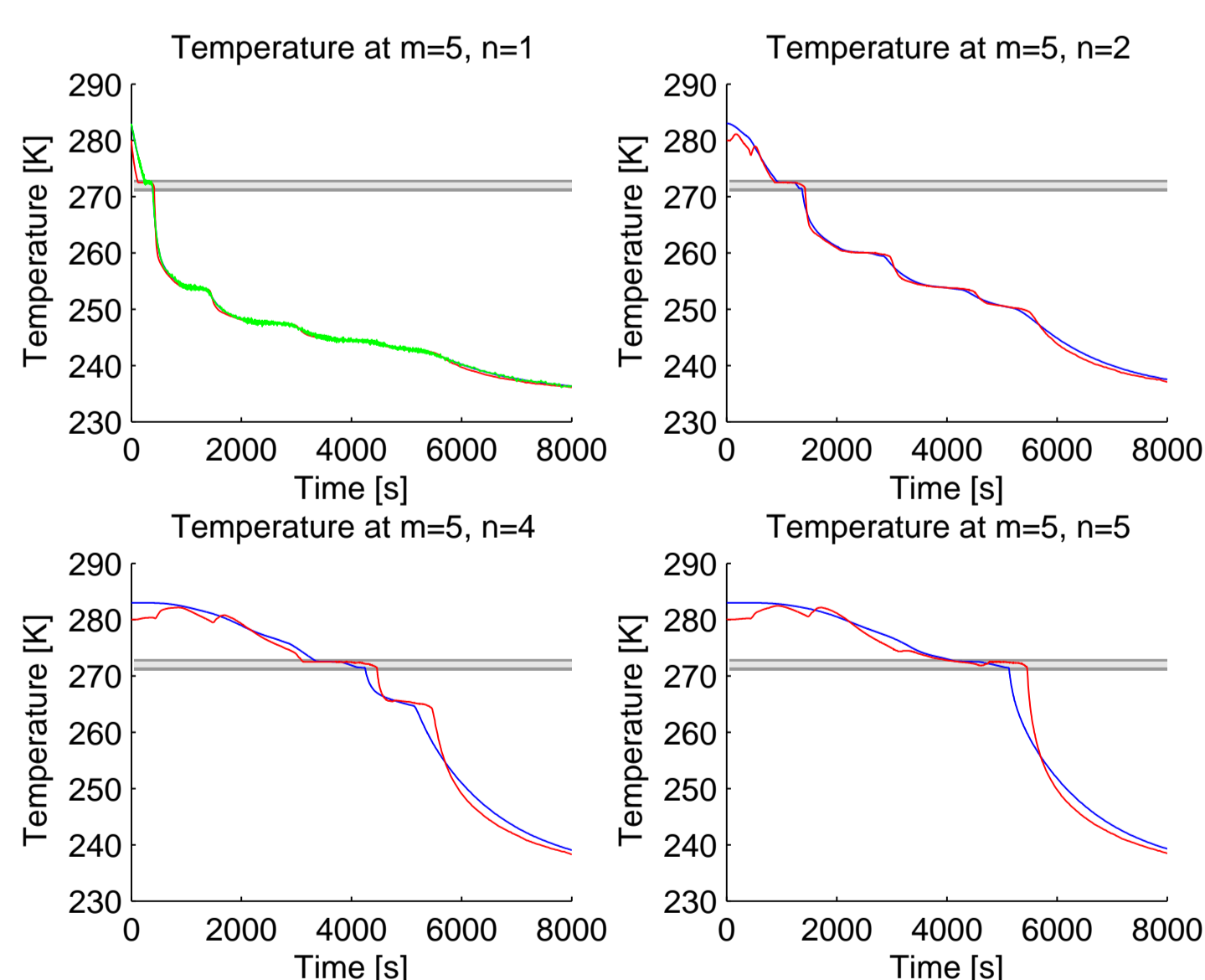

FIGURE 6: Q and R constant
Order of magnitudes Q : 1 – 2 and R : 4 – 5

- White Gaussian noise added to the measurement signals
- Noise covariance matrices $Q = Q^T > 0$ and $R = R^T \geq 0$ are square and diagonal
- Only results for the block's bottom are presented ($m = 5$)

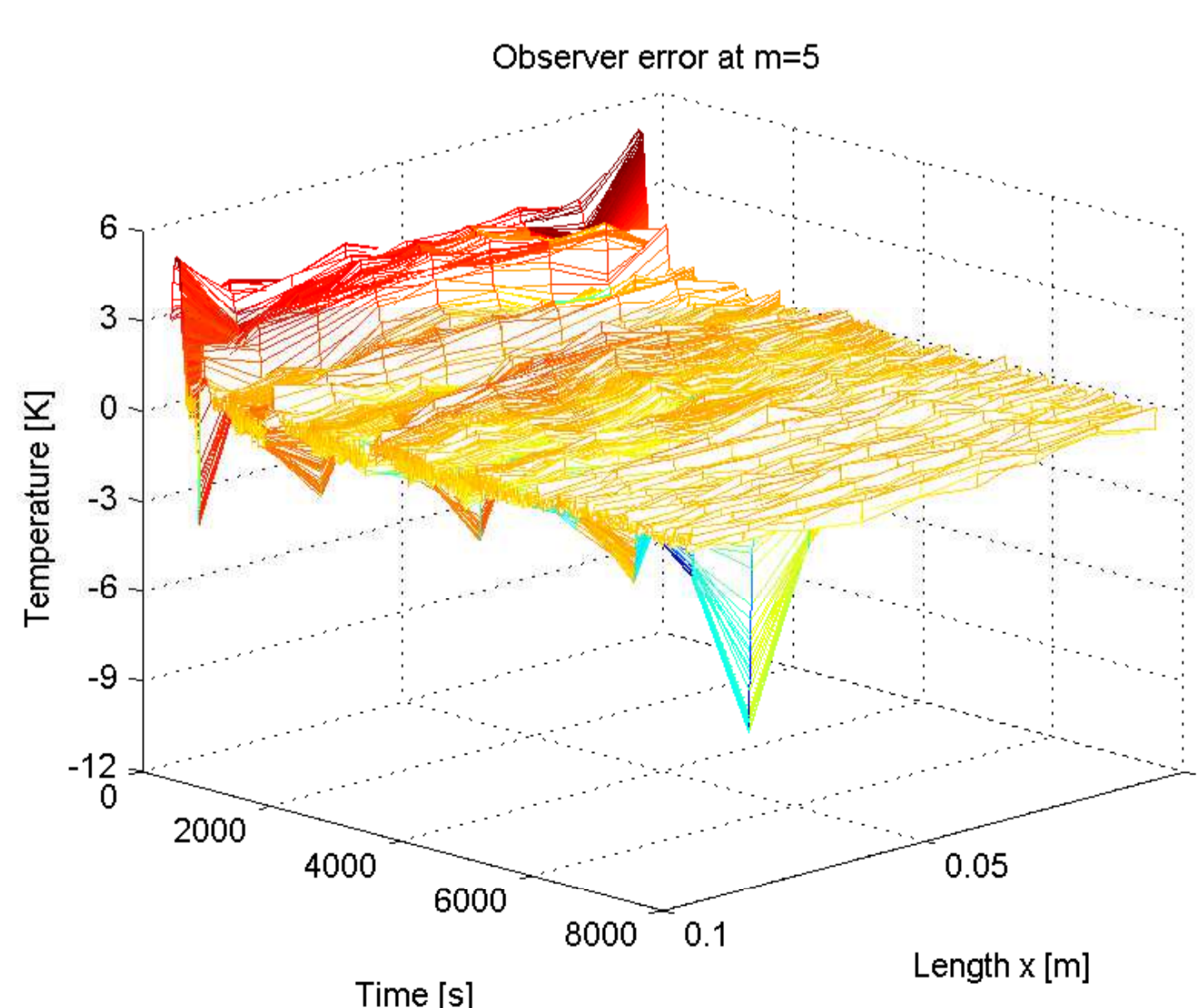
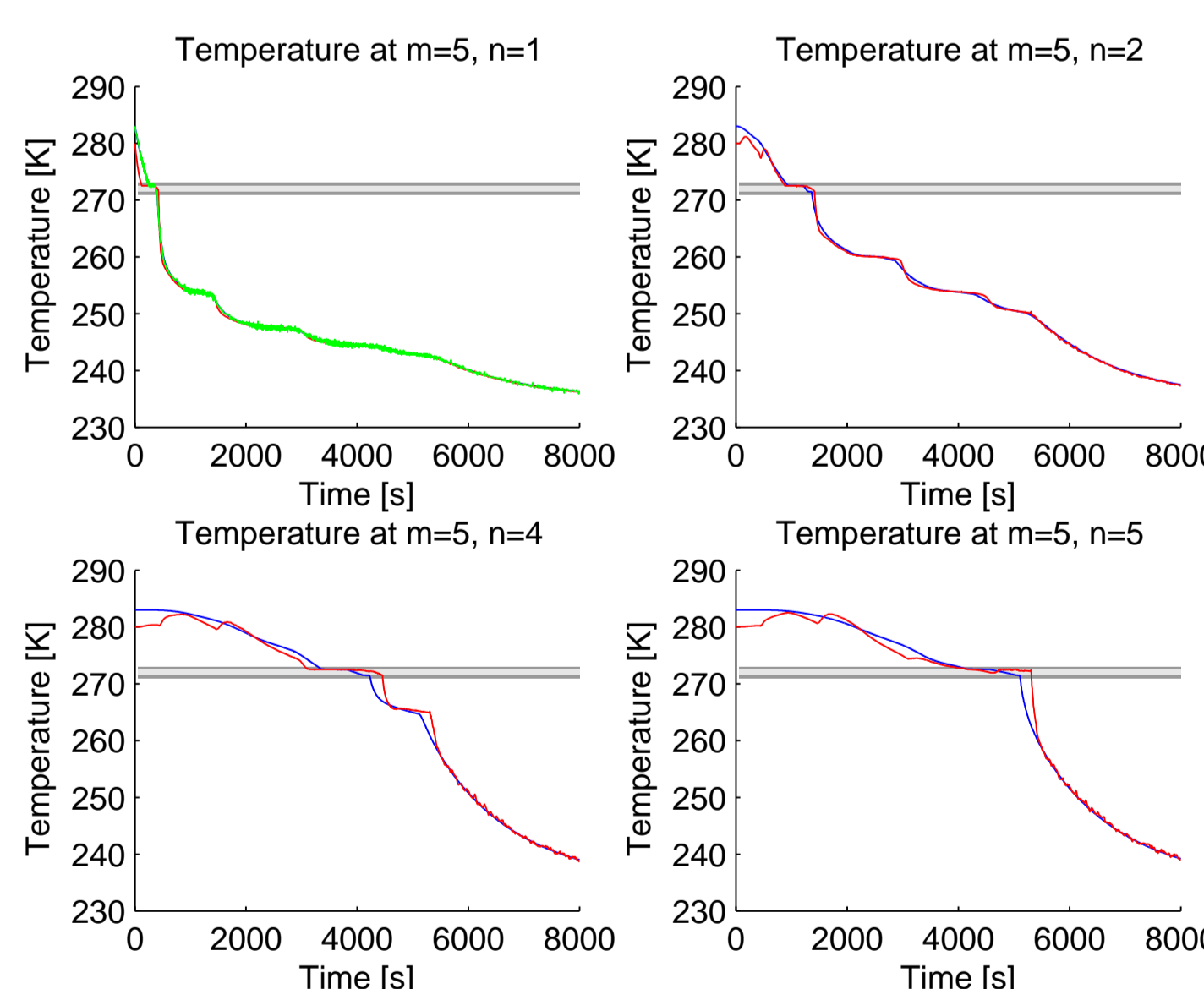

FIGURE 7: Q and R switched when $T_{1,5} < 271$ K
Order of magnitudes Q_1 : 1 – 2, Q_2 : 0 – 2 and R_1 : 4 – 5, R_2 : 2 – 3

DISCUSSION

The presented results were achieved by several simplifications:

- The plate freezer is perfectly insulated at the bottom
- The heat exchange with air is modeled by a Dirichlet boundary condition
- The fish in between the freezing plates is considered as a homogenous mass without any entrapped air

Future work:

- Real-time applicability
- *Late lumping* design, meaning the observer is formulated as a PDE
- Embed the observer inside a control strategy (for example inside an MPC formulation for boundary temperature control)

REFERENCES

- [1] C. J. Backi and J. T. Gravdahl. Optimal boundary control for the heat equation with application to freezing with phase change. In *Proceedings of the 3rd Australian Control Conference*, Perth, Australia, 2013.
- [2] C. J. Backi, J. D. Bendtsen, J. Leth, and J. T. Gravdahl. Estimation of inner-domain temperatures for a freezing process. In *Proceedings of the 2014 IEEE Multi-Conference on Systems and Control*, Antibes, France, 2014.
- [3] M. Muhieddine, É. Canot, and R. March. Various approaches for solving problems in heat conduction with phase change. *International Journal of Finite Volume Method*, 6(1), 2008.
- [4] Q. T. Pham. Modelling heat and mass transfer in frozen foods: a review. *International Journal of Refrigeration*, 29:876–888, 2006.