

TEEKAY PETROJARL PRODUCTION

Lasting av olje – noe å lære av flytting av store kvantum under eksponerte forhold?

**Tekmar, Trondheim 09.12.09
Einar Rygg**



Teekay Petrojarl - historie

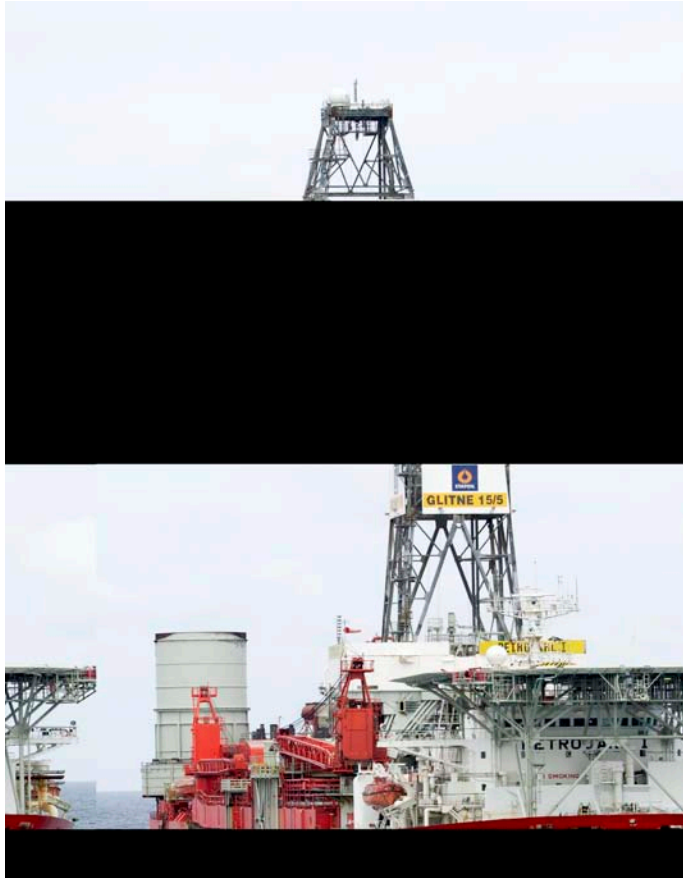

- ▶ Tidligere Golar-Nor Offshore, etablert bore kontraktør i 1974.
- ▶ FPSO kontraktør siden 1984 (Petrojarl I)
- ▶ Oppkjøpt av Teekay i 2006
- ▶ Kontor i Trondheim, Aberdeen and Macae.
- ▶ Over 600 ansatte
- ▶ Største FPSO kontraktør i Nordsjøen:
 - 5 FPSO'er
 - 2 shuttle tankere og 1 FSO

Teekay Petrojarl – hvor?

Physical Map of the World, June 2003



Petrojarl Foinaven



Petrojarl Varg



Petrojarl I



Petrojarl Banff



Ikdam



Petrojarl Cidade de Rio das Ostras

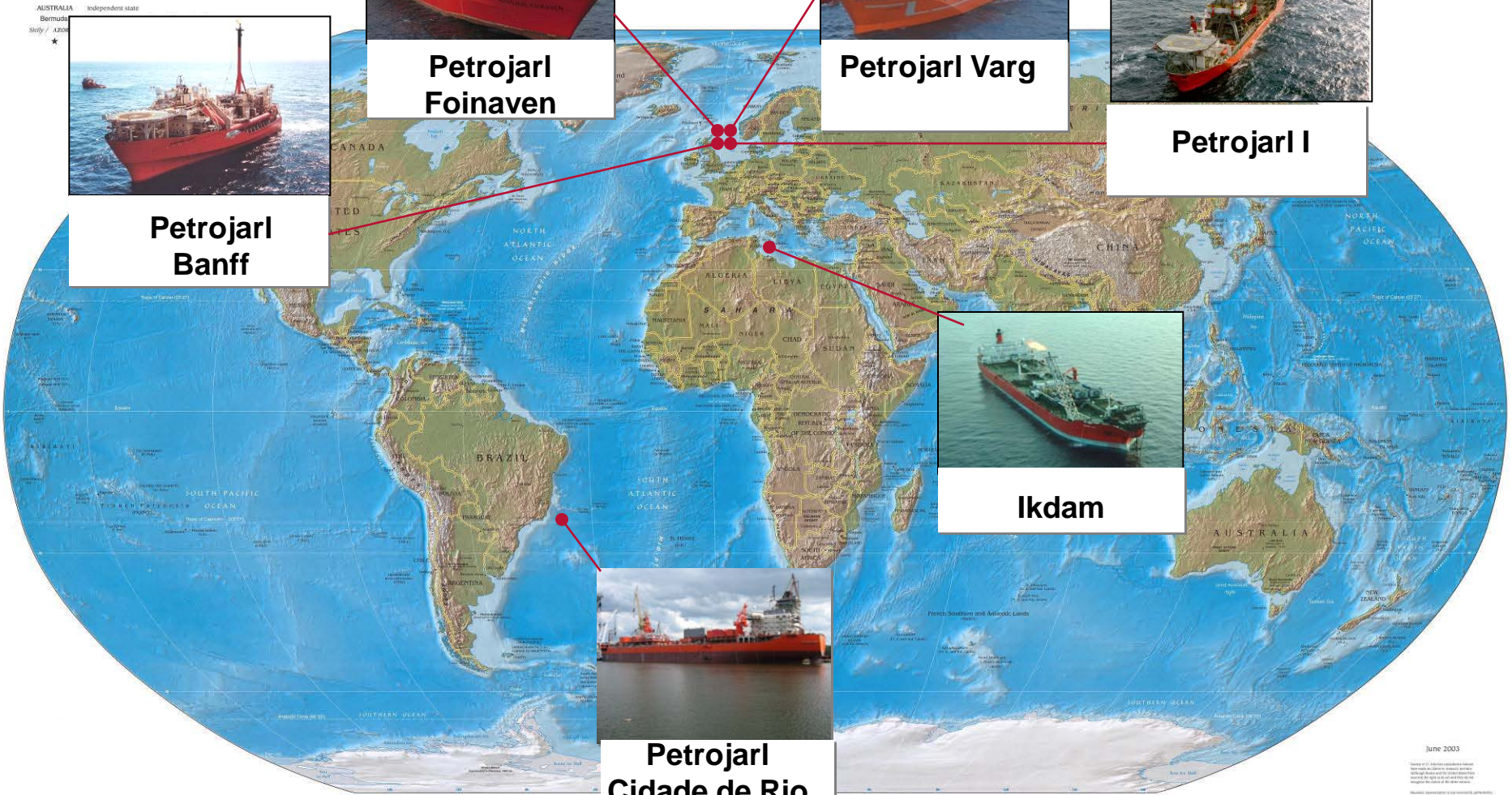

June 2003

Copyright © 2003 by Teekay. All rights reserved. This map is for informational purposes only. Teekay is not responsible for any errors or omissions. The names of the countries and the names of the cities are for informational purposes only. The names of the countries and the names of the cities are for informational purposes only.

FPSO konsept

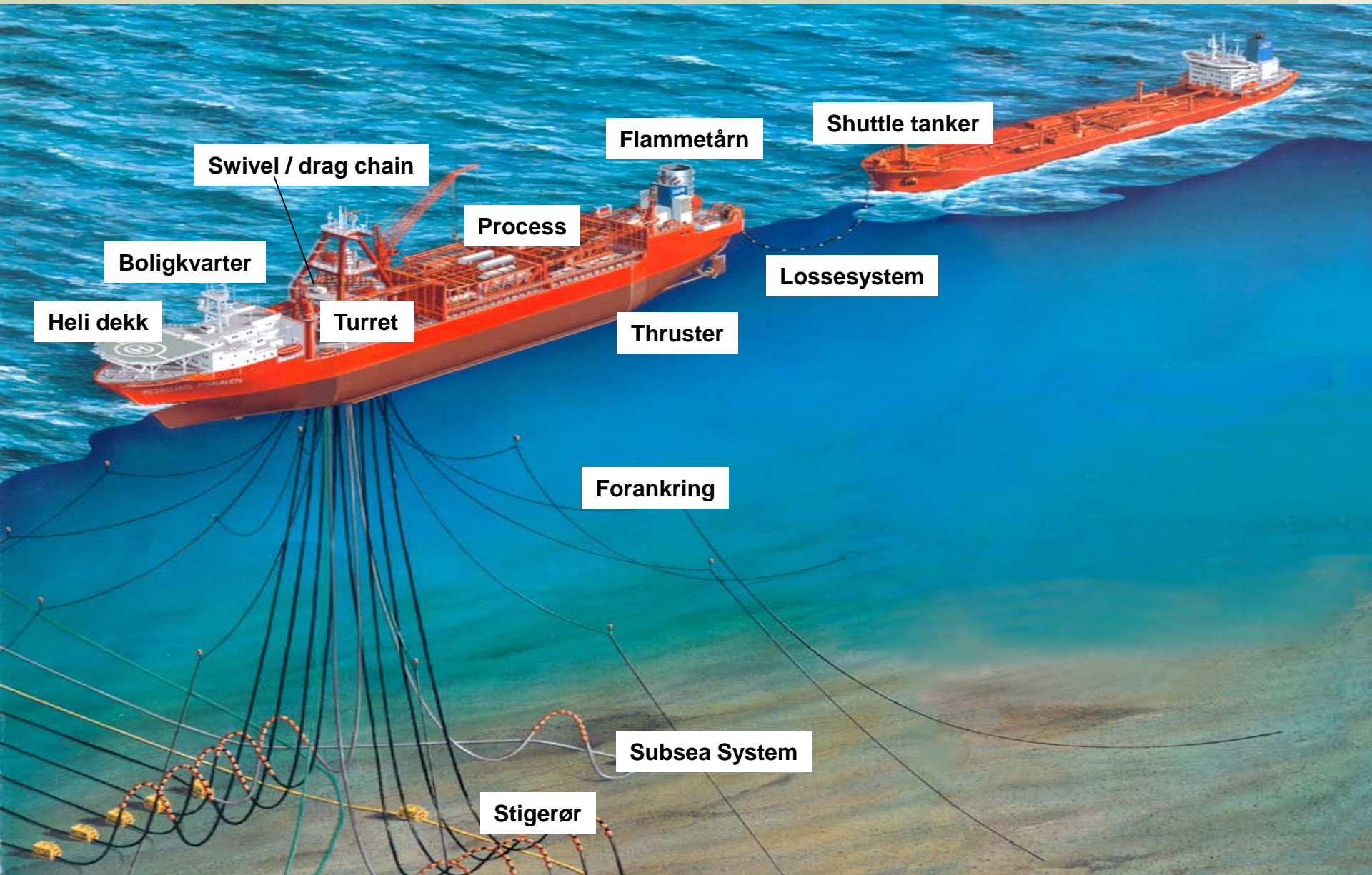

Typiske størrelser

▶ FPSO

- ▶ Lengde 200m
- ▶ Bredde 38m
- ▶ Dypgang 16m
- ▶ DWT 70.000t
- ▶ Kapasitet: 430.000 fat

▶ Shuttle tanker

- ▶ Lengde 230m
- ▶ Bredde 42m
- ▶ Dypgang 14m
- ▶ DWT 93.000t
- ▶ Kapasitet: 650.000 fat



Laste / losseoperasjon

- ▶ Maksimere operasjonstid
 - ▶ Dårlig vær – Hs 5,5m
 - ▶ God avstand mellom fartøy – 80m
- ▶ Rask lossing
 - ▶ Under 24 timer (4000 m³ per time)



Hovedkomponenter lossesystem

- ▶ 9 lastetanker og 2 sloptanker
- ▶ En pumpe i hver tank,
 - ▶ hydraulisk, nedsenket
 - ▶ 800 m³/time
- ▶ Fiskal målestasjon
 - ▶ Kapasitet 4000 m³ pr time
- ▶ Nødavstengingsventil
- ▶ Endeventil
 - ▶ Koblerventil Petrojarl Varg



Losseslange

- ▶ 16" (~40cm) diameter
- ▶ 120m lang
- ▶ 12m seksjoner
- ▶ Inspeksjon ved bruk
- ▶ Årlig trykktest



- ▶ På trommel
- ▶ eller sliskebane



BLS Manifold

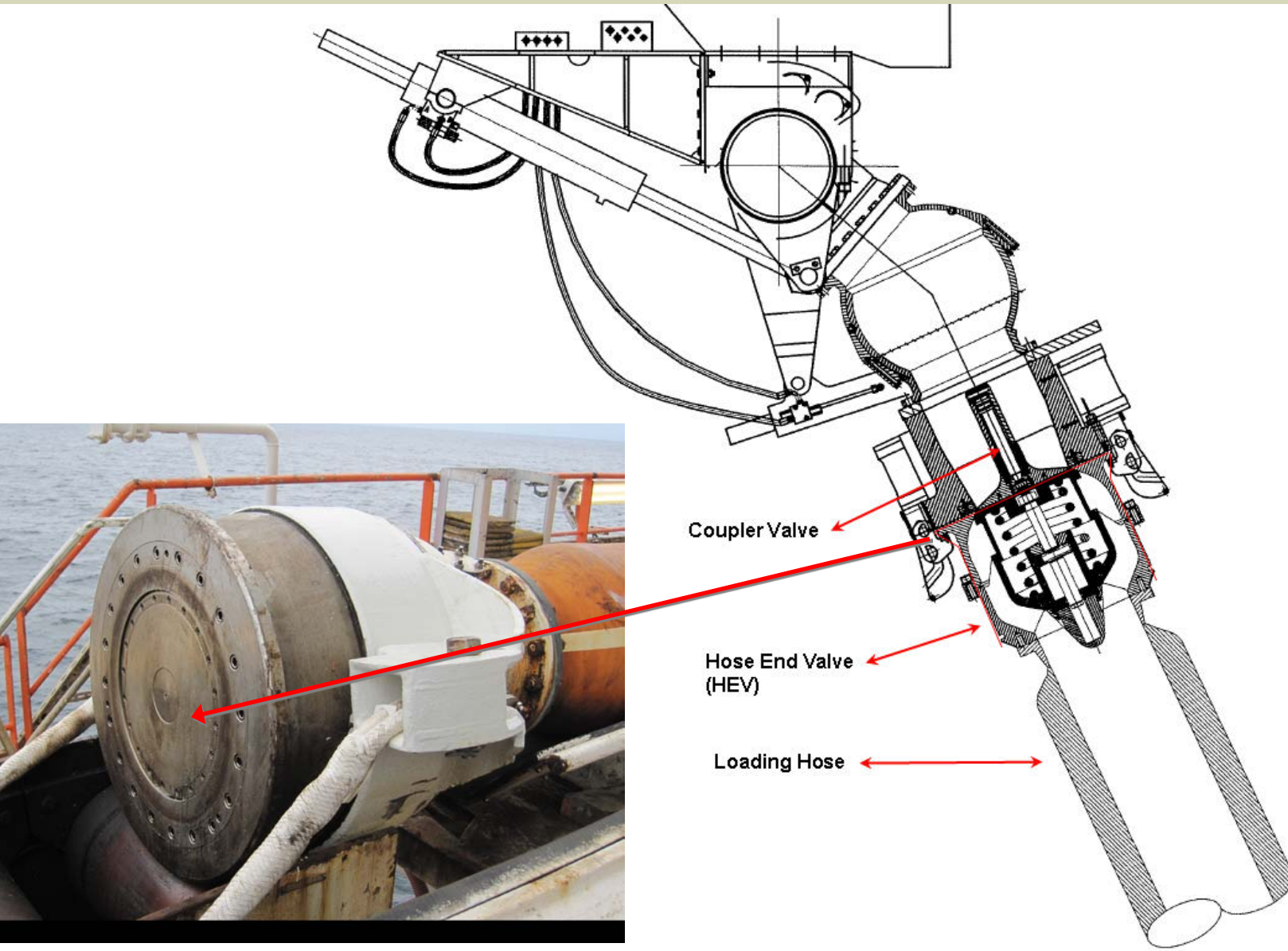

Fortøyning av tankbåt

- ▶ Trosse 85 m
 - ▶ Slitekjetting
 - ▶ Bruddstyrke 570 t
 - ▶ Lastcelle
-
- ▶ Slakk trosse
 - ▶ Tankbåt posisjonering – DP klasse 2



Oversikt tanker og pumper

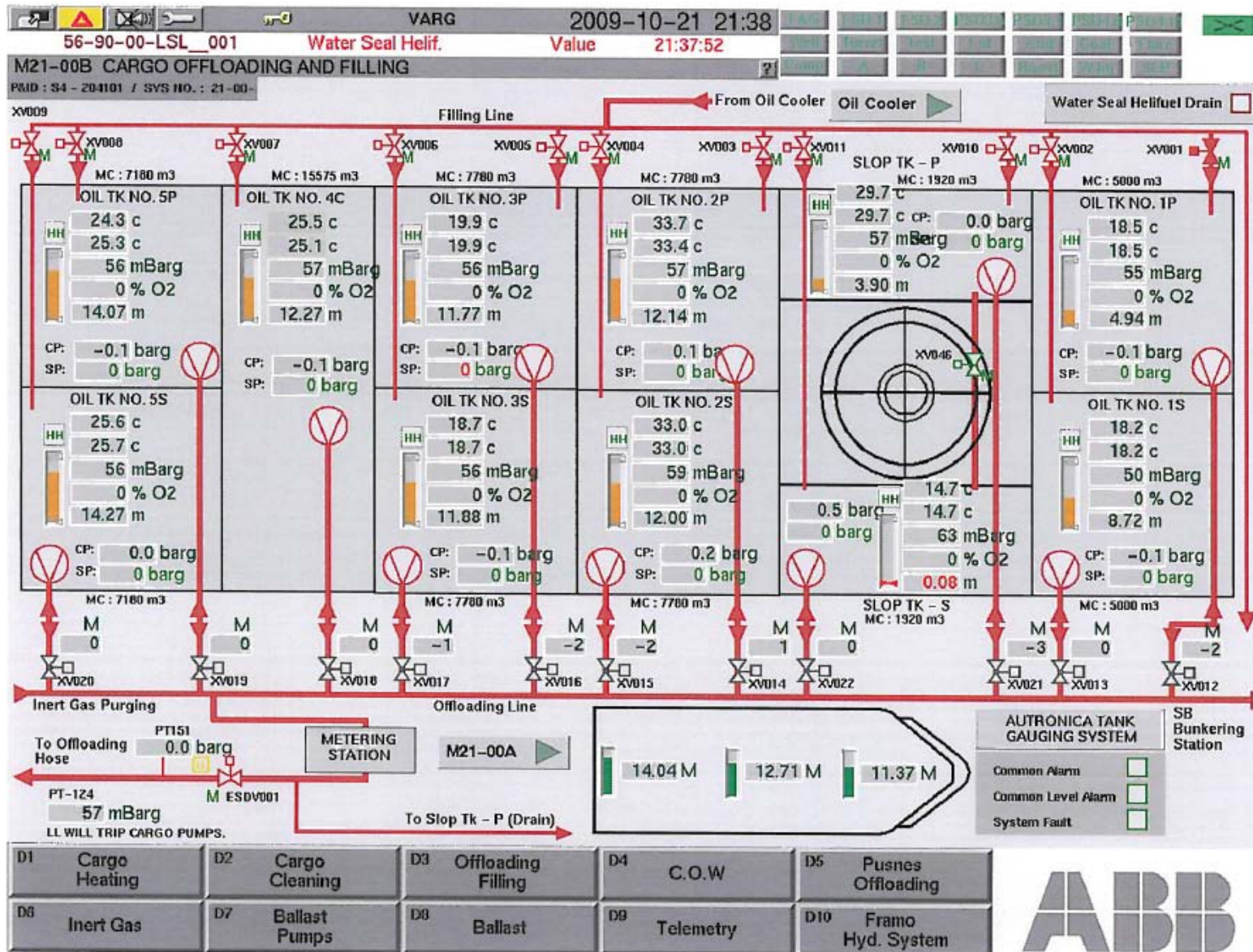

Grønn linje

- ▶ Ventiler for å gi grønn linje blir kontrollert fra "lossebua" akterut samt tankbåt
- ▶ Grønn linje er nødvendig for å kunne starte lossing



Grønn linje

VARG 2009-10-28 21:07
TAG ESD1 ESD2 ESD3 ESD4 ESD5 ESD6 ESD7
Well Turret Test Ext 2nd Coast Flare
M22-00 OFFLOADING SYSTEM ? Comp A B C Boost W/Inj SUP

CRUDE OIL

PRESSURE 0.0 bar

FLOW 0 m³/hr

MOORING BRACKET HAWSER TENSION

0 tonn

HOSE WINCH

HOSE TENSION 0 tonn

HOSE SPEED 0.0 m / min

ALARMS FROM PUSNES CONTROL SYSTEM

<input type="checkbox"/> L Oil Level LL	<input type="checkbox"/> Locking Acc. Pressure Low	<input type="checkbox"/> PLC Failure
<input type="checkbox"/> H Oil Temp HH	<input type="checkbox"/> System Acc. Pressure Low	<input type="checkbox"/> Offloading Line Failure
<input type="checkbox"/> Press. Filter Clogged	<input type="checkbox"/> Hose Tension High	<input type="checkbox"/> Emerg. Stop Offloadin
<input type="checkbox"/> Return Filter Clogged	<input type="checkbox"/> Hawser Tension High	<input type="checkbox"/> SD Class II
<input type="checkbox"/> Drain Filter Clogged	<input type="checkbox"/> Load Cell and Clutch Diseng.	<input type="checkbox"/> Acc. Failure

OFFLOADING PERMITTED

OFFLOADING SD II INITIATED

OFFLOADING STANDBY

OFFLOADING EMERG. STOP

RENDERING PRESSURE

0 bar

HOSE WINCH CONTROL

Central

Remote

Local

CLUTCH

Off On

BAND BRAKE

Off On

HOSE LENGTH ALARM

PRESSURE SELECTION

Stand by Work

HYDRAULIC PUMPS

65-60-00

Pressure Avialbe

A PB101 A PB102 A PB103

OIL TANK

Temp 22.0 °C

Level 0.5 m

Pressure

Hydraulic 0.5 Bar

Locking Acc. 0.6 Bar

System Acc. 273.8 Bar

OFF LOADING LINE

ESD-VALVE	OFF LOADING CONTROL	MOORING CLUTCH	BRAKE LOADCELL	COUPLER VALVE	COUPLER CLAWS	HOSE END POS.
Open <input type="checkbox"/>	Permitted <input type="checkbox"/> Ready <input type="checkbox"/>	Diseng. <input type="checkbox"/>	Connected <input type="checkbox"/>	Open <input type="checkbox"/>	Closed <input checked="" type="checkbox"/>	In <input type="checkbox"/>
Closed <input checked="" type="checkbox"/>	Not Permitted <input checked="" type="checkbox"/> Not Ready <input checked="" type="checkbox"/>	Engaged <input checked="" type="checkbox"/>	Dis Connected <input checked="" type="checkbox"/>	Closed <input checked="" type="checkbox"/>	Open <input type="checkbox"/>	Out <input checked="" type="checkbox"/>

D1 Cargo Heating	D2 Cargo Cleaning	D3 Offloading Filling	D4 C.O.W	D5 Pusnes Offloading
D6 Inert Gas	D7 Ballast Pumps	D8 Ballast	D9 Telemetry	D10 Framo Hyd. System



Kontroll under lossing

- ▶ Sjekklister
- ▶ Prosedyrer
- ▶ Alarmer for:
 - ▶ Høyt / lavt trykk
 - ▶ Høyt / lavt strekk i fortøyning
 - ▶ Feil posisjon av tankbåt
 - ▶ Feil i telemetri – grønn linje
- ▶ Måling av overført volum
- ▶ Stand-by båt

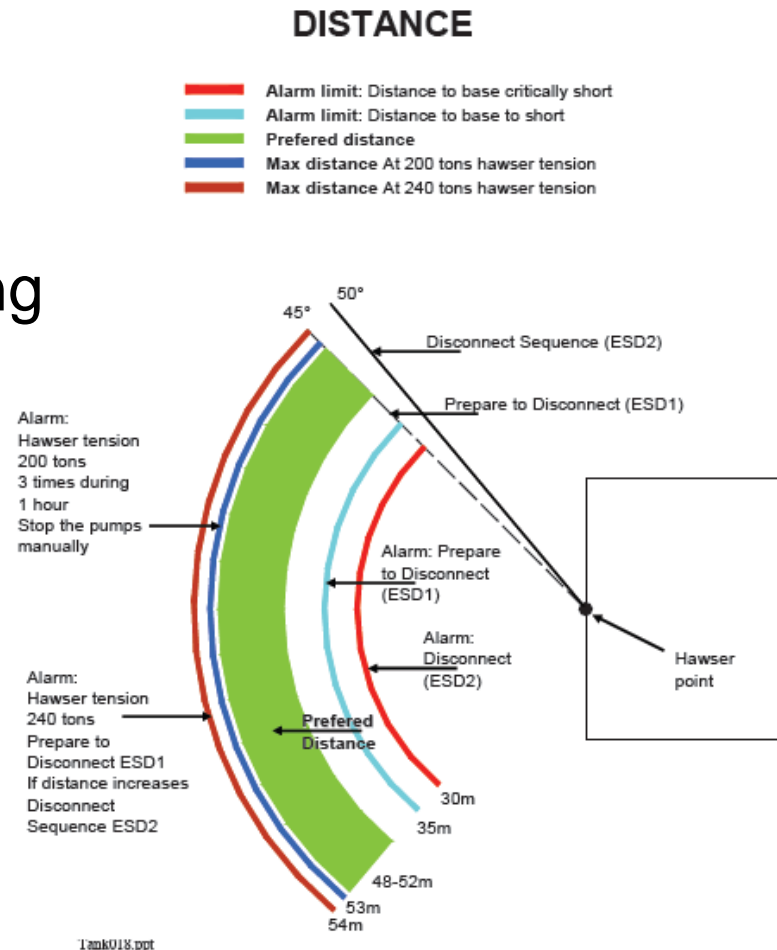

Nødavstenging

▶ ESD I

- ▶ Fra tankbåt eller FPSO
- ▶ Stoppe pumper
- ▶ Lukke ventiler
- ▶ Gjør klar til frakopling

▶ ESD II

- ▶ Fra tankbåt
- ▶ Frakopling av slange
- ▶ Frakopling av fortøyning
- ▶ Sprinkler anlegg på tankbåt

Endt lossing

- ▶ Reversere oppkoping
- ▶ Drenering av olje i rør/slange
- ▶ Fylling av nøytralgass



Petrojarl I – 23 års erfaring

- ▶ Kran for lossing
- ▶ Kort avstand – 45m
- ▶ Stram trosse
- ▶ MBC – "Marine breakaway coupling"



PETROJARL CIDADE DE RIO DAS OSTRAS



PETROJARL CIDADE DE RIO DAS OSTRAS

- ▶ 230m lang slange
- ▶ 135m avstand
- ▶ Men: kontakt med kjetting



Ikdam

- ▶ 300m flytende slange
- ▶ Ende sikres mellom losseoperasjoner
- ▶ Håndtering?



Flytende slanger

