

Feasability Study. Gjennomført av .Merit Maritime Innovations, for COJECT

Feasibility study – Value of jellyfish as a resource and removal of jellyfish in the sea

Dato: 17.09.2010
Versjonsnummer 1



MERIT MARITIME INNOVATIONS AS

Prosjektansvarlig: Atle Grønlie
Tlf.: + 47 99 00 70 07
ag@merit-maritime.com
Oslo, 03.09.2008

1 SUMMARY

Technical

The COJECT has developed and tested a prototype destruction unit for jellyfish, however other parts of COJECT are either on the prototype/model stage or earlier stages. Further comprehensive development is needed to bring the system to the market, especially on the trawl and detoxification units. It seems evident that some form of pre-processing is needed onboard which also need to be developed. It is assumed that considerable funds are needed, and that COJECT probably need to find a partner that is willing and committed to fund the further development of COJECT as the project group itself does not have the available resources. There exist some technology in regards to collagen extraction and pre processing that can solve some of the technical challenges COJECT faces, but no technology in regards of egg destruction and detoxification have been identified.

Market

In the **Asian** market (China, Japan and Korea) the following findings can be seen as a representation for the market possibilities for destruction of jellyfish:

1. There is a regional cooperation programme on jellyfish in northeast Asia, coordinated by government and carried out by research organizations in Japan, Korea and China at national level. Activities under this program include both destruction and utilization of jellyfish. This program is looking for international cooperation in principle. However,
2. Based on this program, Korea and Japan has been developing jellyfish eliminating technologies and products mainly for fishing industry. If COJECT could be in position to receive funding from such an initiative, or if the COJECT could be a supplier of technology to such programme will depend on if COJECT is advanced/better than Korean and Japanese.
3. Other industrial sectors, such as power plant and tourism, have no regional or national program for eliminating jellyfish swarms. But there might be business possibility for COJECT technology/product.
4. *Nemopilema nomurai* is the main species that caused big trouble to other coastal industries. (Note: The cooperation program will publish a book including all jellyfish species around this region.)

If the scope is widened to include a possible refining or harvesting of jellyfish as a resource, in Asia the following conclusions can be drawn:

1. Jellyfish as food is a tradition and well developed in China. *Rhopilema esculentum* Kishinouye is the main species, taking more than 80% of total jellyfish production for culinary uses. Price of raw/whole and salted is low. Processing gives the consumer a large variety choice in a large range of price. Market for jellyfish is big and continuous increasing. Coastal jellyfish fishing production can not meet food market demand. Jellyfish farming, sea enhancement and importing are on-going as well. Processed jellyfish products have been exported to many countries especially in Asia. Japan and Korea are using jellyfish as food as well although it is not a strong tradition compared to China. In recent years, more and more attentions and R&D efforts to develop jellyfish food products have been taken place while solving jellyfish caused problems.

2. Amino acids only few research articles but no business information about market players and business for deriving amino acids from jellyfish in this region.

3. Collagen There exist R&D activities on developing nutrition/health products based on both R&D organizations and companies in this region. Some research organizations and companies have been mentioned, but the commercialization has not been well proved yet. Japanese and Korean cosmetic companies are leading group.

4. Feed additives R&D and application for feed is not really started yet, except few research articles.

5. Other R&D and applications

a) Cosmetic and food & beverage additives R&D and applications in Korea;

b) Soil conditioner and cosmetic R&D and application in Japan;

c) R&D and commercial production of nutrition liquid/health drink, Chinese traditional medicine application, R&D on extracting jellyfish venom (toxin) and its pharmaceutical.

Africa

Even though it has been widely recognized that the jellyfish invasions off the coast of western Africa is a problem, there seems to be very little activity in regards of countering the problem. Main research projects are focusing on understanding the behaviour and environmental aspects of the jellyfish and the reasons for the invasions. MMI has not been able to find any evidence that the jellyfish represent a threat to the tourism on the African coast, however this might be related to the absence of information in general from Africa.

Europe

Europe's focus on jellyfish is in regards to the increasing problems the jellyfish swarms cause to the tourism. Especially Spain, Italy and France have reported infestations and in some cases there have been reports on countermeasures (nets and barriers) and actions taken to reduce the threat to the countries' tourists. There are however no evidence to dealing with the source of the problem and battling jellyfish in the open seas. For the time being, jellyfish is not being utilized in any way in Europe.

Fishfeed:

- Amino acids need to be mapped, nutrition value
- Protein source worldwide is available in large quantities
- 1 ton of protein equals 1000 tons raw jellyfish
- Price of traditional protein resource (65% proof) is 700-1500 \$/ton ~10.000 NOK pr ton (100% proof)
- Unknown if fish/marine creatures will eat it
- NFRDI claims that minced jelly fish could become an effective feed for younger fish at fish farm site, and Chinese are researching feed for snow crabs.

Based on this does it not seem plausible to commercially catch jellyfish for its protein (collagen) exclusively. (cod price ~12.000 NOK pr ton)

Consumption:

- Certain jellyfish are more valuable than others, for example Nomura jellyfish is not widely used because of taste

- Jellyfish need to be treated gently, making the harvesting more complex
- Time-consuming processing requires low cost labour or new technology
- Market is located mainly in Asia

Collagen:

- 1 ton of protein equals 1000 tons raw jellyfish
- Price of refined consumable collagen is: 10-20 \$/kg
- Method of extracting collagen (IPR) is owned by others
- Quality of collagen determines application area and price
- In total, given no other financial costs than fuel to decanters and day rate of the boat, a boatload of jellyfish would have expenses that exceed the income ~ 50.000 \$ (based on 6 days of operation).

Destruction

- Unwillingness to pay for service as jellyfish drift around and are not place bound
- Estimates of fisheries enhancement needs to be verified
- Uncertain income model
- Local tourism enhancing bodies might be interested

IPR

- As a result of a relatively brief patent prior art search, it is our opinion that the Coject technology, limited to a hydraulically-driven shredder at the end of trawl net provided with counter-rotating chopping blades, is patentable. In addition, this brief work invites us to believe that the Coject technology would have good chances not to meet any major Freedom To Operate challenge.

Funding

- Private investors need to see the potential, no interest identified among Norwegian players
- Global Soft funding (NORAD, IFAD (FAO)) is possible, but probably need local governmental projects.
- Local soft funding (joint programmes in Asia etc) do not generally block foreign initiatives, but might need to be proven better than local initiatives (Japan etc)

Based on the abovementioned items it doesn't seem plausible to harvest and process jellyfish for its valuable dry matter (collagen). The process of harvesting and process such huge amounts of jellyfish to produce 1/1000 parts collagen, will demand too much energy and time to produce a product (depending on quality) in the range of 1000\$/ton. Further refining is possible, but at the moment not scalable, and the quality of the end product is hard to define.

Destruction of jellyfish as fishery enhancement has no clear return of investment, and it seems therefore unlikely that it will attract private funding, leaving governmental and organisational funding. As identified such funding is generally given through local projects and organisations, often in partnership with a NGO or UN body. However such projects and funding leaves COJECT with a highly uncertain potential income, depending on business model. Joint venture with a research body, such as Havforskningsintitutet or similar organisations might give better leverage when approaching these types of funds.

2 Index

SUMMARY	2
Index 5	
1. Purpose of document.....	6
2. Background of COJECT	6
3. Technology and business concept	7
Business concept	7
Technology.....	7
4. The jellyfish threat	9
Fisheries and ecosystem	9
Tourism and medical threat.....	10
5. Jellyfish as resource	11
Consumption, human food	11
Collagen	17
Fish/marine animal feed	23
Medical.....	24
6. Market scan.....	26
Korea	27
Japan.....	30
China	36
Europe	40
Africa.....	41
7. Areas of application	41
Destruction of jellyfish.....	41
Harvesting jellyfish for processing	41
8. Technical/commercial handshake.....	41
9. IPR.....	45
Background	45
Summary	45
The Coject technology described in NO20072921	45
Cited Patentstyret patents	45
Other interesting prior art.....	46
Discussion	48
Methodology and searches	48
10. Funding.....	48
11. Conclusions and summary.....	51

3

1. Purpose of document

The purpose of this document is to look at the different applications the new COJECT technology can be put to use in countering the global jellyfish threat. There exists a growing concern that the increased jellyfish biomass in the world's oceans will result in a decreasing amount of the world's fish resources. The jellyfish is not only a threat to fisheries, it also represents a possible resource, either for direct consumptions or as a resource for refined products, such as nutrition for fish/shrimp/shellfish in aquaculture farming or as a collagen source in pharmaceutical or nutrition industry. This document aims to look at the different applications of jellyfish and their challenges and identify the best way forward in terms of revenues for the COJECT, and thus form a basis for the COJECT to make executive decisions.

2. Background of COJECT

The inventor Børre Høver has for a long time shown interest in the jellyfish situation and the current and possible impact on the world's fisheries and tourism, as there are no working solutions to battle the increasing biomass of jellyfish in the oceans. Some nations have tried solutions for reducing the jellyfish stock and prevent jellyfish from entering beach areas, but with little success. Examples is screening beaches with oil lenses and using nets to collect the jellyfish, and Japan has tried trawling with thin steel wires in order to kill jellyfish in certain areas off the nations coast in order to improve fisheries.

The common denominator of these techniques and installations is that they don't serve the purpose of getting rid of the jellyfish invasions, and thus Mr Høver has over a long period of time worked with solutions to these problems. It is important to not only see the jellyfish as a problem, but also realise the potential resource the jellyfish represent, and look at solutions where not only you remove the jellyfish from certain areas, but also utilize the biomass jellyfish represents.

Mr Høver has entered into a partnership with several key persons that have come to form the COJECT group. The COJECT group have expertise in engineering, marine biology and mechanical manufacturing, all vital for the evolution of COJECT.

3. Technology and business concept

3.1 Business concept

The COJECT business concept will be a possible 2 step utilization of the jellyfish resource.

1. Collection and killing of jellyfish
2. Process and refining of jellyfish into one or more suitable products

The business concept of COJECT is to develop and introduce technology for the harvesting and destruction of jellyfish biomass of the world's oceans. As a first line implementation and proof of concept is to establish a venture that can capture and kill jellyfish in order to enhance fisheries in certain areas infested with large amounts of jellyfish. The COJECT consists of a collection unit (trawl) and a destruction unit (turbine/grinder) that kills jellyfish and immediately feeds the killed jellyfish (chopped into small pieces) into the ocean area where it was collected.

The technology need to be fine tuned in regards to what the average size of jellyfish being targeted, since they come in all size and shapes from a few centimetres to 2 meters in diameter.

Further processing of the jellyfish will need add-on equipment to be fitted, ie pumps, dehydration and storage on the capturing vessel, and probably a processing plant of some sort on-shore or even on the vessel.

3.2 Technology

COJECT is currently the owner of the technology in regards to harvesting/killing the jellyfish. COJECT have solutions for selective collection of jellyfish, killing and removal of toxins and eggs from jellyfish. The technology is not high end, and is probably operable by individuals with very little technological knowledge. The technology can be owned by COJECT, licensed or transferred to a suitable partner. COJECT does not have the technology to process jellyfish into refined goods, and need to find knowhow or partners that can add this to the project. COJECT are also seeking additional areas where the technology can be utilized.

The COJECT is a system combined of several elements:

1. Selective trawl – conceptual, a model has been made
2. Destruction unit – prototype tested, further developed
3. Detoxifier/egg destroyer – conceptual
4. Pumping unit (optional)– conceptual

For the time being, only the destruction unit has been piloted and tested. The testing was performed on the research vessel Fridtjof Nansen in 2008, with promising results. Based on these tests the prototype was then modified and shipped for further testing in 2009. These tests failed as a result of the unit's buoyancy element collapsing as the operators trawled at deeper water than design depth. Further testing has not been done.

The trawl which selectively catches jellyfish and nothing else has been designed and a small scale model of the trawl has been made. No testing to verify the effectiveness has been done.

Detoxifier/egg destroyer is a conceptual device that utilizes ultra sound to crack jellyfish eggs and trigger the stingers. This unit is believed to be needed in order to limit the number of eggs released when a jellyfish uses its last resources to reproduce itself when threatened, and to detoxify the jellyfish.

The pumping unit will be needed if jellyfish, as whole or in pieces, is to be loaded onto a boat/ship for further processing. The pump itself is a mainstream unit, however the piping from the trawl to the surface needs to be designed and tested.

4. The jellyfish threat

3.3 Fisheries and ecosystem

Dense jellyfish aggregations can be a natural feature of healthy ocean ecosystems, but a clear picture is now emerging of more severe and frequent jellyfish outbreaks worldwide. In recent years, jellyfish blooms have been recorded in the Mediterranean, the Gulf of Mexico, the Black and Caspian Seas, the Northeast US coast, and particularly in Far East coastal waters.

Once jellyfish gain a foothold, if conditions are right, they can establish a massive population at the expense of other ocean life which results in parts of the ocean might switch from being dominated by fish to being dominated by jellyfish.

A new study appearing in *Trends in Ecology and Evolution*, explore the causes behind the jellyfish infestation and the need for swift, decisive action to stem the jellyfish take-over. Jellyfish explosions are linked directly to human actions, including over-fishing, the input of fertilizer and sewage into the ocean, and climate change.

Overfishing has removed fish from marine ecosystems at astounding rates. According to the study this has opened the door for jellyfish to take their place because small fish (e.g. anchovy, sardine and herring) appear to keep jellyfish in check by predation (on jellyfish when they are very small) and competition (for the same zooplankton food). So, once the fish is removed, jellyfish can proliferate. This is the case in Namibia where intense fishing has decimated sardine stocks and jellyfish have replaced them as the dominant species.

Eutrophication is another human-caused change in the ocean that has likely contributed to jellyfish explosions. Eutrophication is an increase of nitrogen and phosphorous in the ocean, largely caused by fertilizer and waste runoff seeping into the oceans. This leads to algae blooms, which lower oxygen in the marine ecosystem creating so-called 'dead zones', which have been increasing dramatically around the world.

These low-oxygen waters give jellyfish the advantage as fish avoid low oxygen water but jellyfish, having lower oxygen demands, not only survive but can thrive in these conditions as there is less predation and competition from fish.

Furthermore the study speculate that climate change may expand the traditional ranges of jellyfish at the expense of other marine species as water warms, tropical species are moving towards the Poles. This has been documented on land and in the sea. Many venomous jellyfish species are tropical (e.g. box jellyfish and irukandji) and could move north and south into more densely populated subtropical and temperate regions.

As an example the paper points to box jellyfish and the incredibly small irukandi in Australia. These fatal species often cause beach closures in their native northeast Australia, and there is a concern that as the water warms they will make their way to more populous southern Australia.

Once jellyfish appear en masse in an ecosystem they can make it very difficult for fish to stage a come-back. By feeding on fish eggs and larvae in addition to competing with fish population for zooplankton, the jellyfish successfully suppress fish from returning to their normal population numbers. One can thus think of two alternate states with each being stable;

one dominated by fish and the other by jellyfish. Unfortunately, when there is a jellyfish dominated state then this does not support the higher trophic levels of other fish, marine mammals, and seabirds. In other words an ecosystem that loses fish also loses the species that depend on fish for survival.

The study describes this state as a “monoculture of jellyfish”; an apt analogy since the situation shares similarities with other monocultures. When the rich biodiversity of tropical forests is replaced by a plantation growing a single species of tree, an area of rich variety becomes a desert in terms of biodiversity, as do ocean ecosystems when jellyfish become the dominant species.

Due to the difficulty of turning an ecosystem around once jellyfish have gained the upper hand, focusing on prevention rather than cure is probably the best way forward. However, in order to re-establish a normal ecosystem, the jellyfish population needs to be reduced for the system to heal itself.

They recommend a halt to overfishing small fish that are vital to keeping jellyfish in check such as sardines, anchovies, and herring; reducing the amount of fertilizer and sewage running off into the oceans, thereby mitigating dead zones; and finally confronting climate change.

While jellyfish are edible, it is doubtful that they could serve as rich—or as diverse—a food source as marine fish. But they may serve as a potential resource for numerous other uses.

Far worse than civilization forced to turn to a jellyfish diet is the ocean emptied of fish, big and small, predator and prey; an ocean that no longer supports birds in great flocks or marine mammals at all.

Areas that are currently particularly hard-hit by these squishy animals include Hawaii, the Gulf of Mexico, the east coast of the U.S., the Bering Sea, the Mediterranean Sea, Australia, the Black Sea and other European seas, the Sea of Japan, the North Sea and Namibia.

Massive jellyfish swarms--some of which cover hundreds of square miles--have caused injuries and even occasional deaths to water enthusiasts, and have caused serious damage to fisheries, fish farms, marine mines, desalination plants, ships and nuclear power plants. Since the 1980s, jellyfish swarms have cost the world’s fishing and tourism industries alone hundreds of millions of dollars and perhaps even billions of dollars.

From large swarms of potentially deadly, peanut-sized jellyfish in Australia to swarms of hundreds of millions of refrigerator-sized jellyfish in the Sea of Japan, suspicion is growing that population explosions of jellyfish are being generated by human activities. Human activities that have been suggested by media reports and scientists as possible causes of some jellyfish swarms include pollution, climate change, and introductions of non-native species, overfishing and the presence of artificial structures, such as oil and gas rigs. But which of these human activities, if any of them, are really to blame?

3.4 Tourism and medical threat

Beaches from Marseille to Monaco have been plagued this summer (2009) by millions of the gelatinous invaders, whose burning stings have sent scores of holiday-makers fleeing the surf with yelps of pain since large numbers of jellyfish were first sighted along France's coast in

June ¹. And those menacing the shorelines are simply the outriders of giant shoals that marine biologists have identified hovering between Corsica and France's southern shores. Sections of that invertebrate mother ship are blown to land by unpredictable shifting winds that can turn coastal water into jellyfish marshes overnight — and then leave the same area virtually stinger-free the following day. A large part of the current jellyfish scare is that swimmers rarely know whether the water into which they're wading is benign Mediterranean surf or a dense minefield of tentacles.

The anxiety of the vacationers is forcing some tourism-dependent cities to take defensive measures. Several municipalities have prohibited swimming when the glob-to-human ratio gets too high. Such bans risk provoking the wrath of sweaty vacationers, but the alternative can be grim: on July 15 alone, rescue crews were called to the beaches of suburban Nice nearly 500 times to treat people for jellyfish stings.

Though jellyfish stings don't match shark attacks as a threat to human life — fatalities are usually linked to a few highly toxic species or (more frequently) shock and drowning resulting from multiple stings to people who swim into dense shoals — some French towns battling *la meduse* have adapted defensive methods from shark-plagued resorts elsewhere in the world. Cannes, for example, has invested nearly \$50,000 in floaters and netting to create jellyfish-free zones the size of Olympic swimming pools at two of its most popular beaches. Similar systems have been deployed in Monaco and along certain sections of Marseille's coast. Though nets boast near perfect records in protecting bathers from stings, they do nothing to counter the larger jellyfish onslaught. Last year, Cannes shovelled over 11 million tons of the gooey creatures off its beaches — just a tiny fraction of a population that floats away to sting another day.

The bad news, according to experts, is that there's more of that gummy pain on the way. Overfishing and other destructive human activity have prompted the prolific multiplication of jellyfish by decimating their natural predators: tuna, sharks and turtles. That, and the fact that global warming has raised the water temperature of the Mediterranean by a degree, has produced an explosion of the jellyfish population and a prolonged presence of the creatures in waters where humans like to flounder. Traditionally, scientists say, jellyfish turn up along France's coastline every 10 to 12 years, for a period of four to five years. This is the eighth consecutive year that ever larger populations of jellyfish have camped out off the south of France — a trend experts say is unlikely to reverse itself since it reflects a domination of jellyfish over rivals in the food chain. Similar evolution has been noted in recent years off Spain, Italy and Greece and Asian countries like Japan, China, Indonesia and Korea.

5. Jellyfish as resource

3.5 Consumption, human food

While jellyfish are shunned by swimmers in most places, several species of scyphozoan jellyfish with mild stings are edible. Edible jellyfish are largely estuarine in nature, aggregating around river mouth drainages and primarily caught from the Indian, Northwest

¹ <http://www.time.com/time/world/article/0,8599,1825244,00.html>

Pacific, and Western Central Pacific Oceans by several countries including Thailand, Indonesia, Malaysia, the Philippines and China (Huang, 1988). Among the edible species *Rhopilema esculentum* Kishinouye is the most abundant and important species in the Asian jellyfish fishery which represents a multi million dollar seafood business in Asia (Omori & Nakano, 2001). Processing jellyfish in Asia is a low-cost operation that requires little capital but is labour intensive. Annually 400.000 tons² of jellyfish are caught worldwide for consumption (mainly in Asia), 13 countries participates in the fisheries.

Jellyfish have been exploited commercially by Chinese as an important food for more than a thousand years. Semidried jellyfish represent a multi-million dollar seafood business in Asia. Traditional processing methods³ involve a multi-phase processing procedure using a mixture of salt (NaCl) and alum (AlK[SO₄]₂ · 12 H₂O) to reduce the water content, decrease the pH, and firm the texture. Processed jellyfish have a special crunchy and crispy texture. They are then desalted in water before preparing for consumption. Interest in utilizing *Stomolophus meleagris* (L. Agassiz), cannonball jellyfish from the U. S. as food has increased recently because of high consumer demand in Asia. Desalted ready-to-use (RTU) cannonball jellyfish consists of approximately 95% water and 4–5% protein, which provides a very low caloric value. Cannonball jellyfish collagen has shown a suppressing effect on antigeninduced arthritis in laboratory rats⁴. With the great abundance of cannonball jellyfish in the U. S. coastal waters, turning this jellyfish into value-added products could have tremendous environmental and economic benefits.

Jellyfish processing

Fresh jellyfish readily spoil at ambient temperature. Therefore, processing of jellyfish is carried out preferably within a few hours of capture while the animals are still alive. The body of jellyfish consists of a hemispherical transparent umbrella. The mouth is on the undersurface of the umbrella and is protected by fused oral arms, commonly known as 'legs'. The umbrella and oral arms of jellyfish are separated immediately after catching. Jellyfish are cleaned with sea water, scraped to remove mucus membranes and gonadal material. Both umbrella and oral arms are used in processing. Traditional methods of processing involve a step-wise reduction of the water content using salt and alum. A salt mix containing about 10% alum is used for initial salting of jellyfish using about 1 kg salt-alum mix for 8–10 kg of jellyfish (Subasinghe, 1992). Salted jellyfish are then left in the brine for 3–4 days, followed by several transfers to another container salted with fresh mix containing a smaller amount of alum. The salted jellyfish can then be heaped and left dry on a draining rack at room temperature for 2 days, and the heap is turned upside down several times during that period to allow excess water to drain out through compression by its own weight. The entire process requires 20–40 days to produce a salted final product with 60–70% moisture and 16–25% salt (Huang, 1988; Subasinghe, 1992). The processed jellyfish has a yield of about 7–10% of the raw weight depending on the species and processing formula. Preservation of jellyfish in a mixture of salt and alum is necessary to obtain products of desirable structure and texture. Alum reduces pH, acts as a disinfectant and a hardening agent, giving and maintaining a firm texture by precipitating protein (Huang, 1988). Salt aids in reducing the water content and in keeping the product microbially stable. Salt or alum used singularly in the processing of jellyfish does not produce a product of satisfactory properties (Wootton et al., 1982). Extensive liquidation of the tissue occurs in the absence of salt, while disagreeable odors

² <http://www.trade-seafood.com/species/jelly-fish-commercial-species.htm>

³ <https://springerlink3.metapress.com/content/x7204250k4174gwt/resource-secured/?target=fulltext.pdf&sid=5svylk45lqxnyi553alae245&sh=www.springerlink.com>

⁴ <http://www.logikbase.com/website/techprofile.cfm?licid=596>

develop in the absence of alum. In Malaysia and Thailand, a small amount of soda is often added in addition to salt and alum. Addition of soda facilitates water dehydration in the curing solution and increases the crispiness of the cured jellyfish. In China, soda is omitted. Because there are large variations among species, and even with different batches of the same types of jellyfish, processors vary the amounts of alum and soda in the salt from one batch to the next to achieve standardization of product. Processing jellyfish is more of an art than an exact science, hence Asians employ JellyfishMasters who make adjustments in the amount of salt, alum, soaking periods and compression to obtain the right quality of product (Rudloe, 1992). Exact procedures are often kept as trade secrets. Processing reduces the pH from about 6.6 in fresh cannonball jellyfish to 4.5–4.8 (Table 1). The lowered pH greatly reduces the possibility of microbial growth and enhances the shelf life of the product. The quality of salt affects the ash content in processed jellyfish. Low grade curing chemicals and processing equipment can be the source of heavy metal contamination (Hsieh et al., 1996). Refined curing agents should be used for jellyfish processing. Cured jellyfish has a special crunchy and crispy texture that makes it unique. The price also depends on the quality of the processed jellyfish as measured by its texture, a combination of tender, elastic and crunchy characteristics, and its colour. The colour of freshly processed jellyfish is creamy white, but gradually turns yellowish as the product ages. In the Asian jellyfish market, a whiter coloured product has higher retail value. Yellow, but not a brown colour, is acceptable. The longer the sample remains around, the darker it becomes. If it remains too long, it turns brown and the product is unacceptable. The salted jellyfish has a stable shelf life up to 1 year at room temperature. The shelf life can be increased to more than 2 years if the product is kept cool, however, freezing spoils the product, which dries out completely and becomes covered with wrinkles. Prolonged storage at warm ambient temperature may cause a loss of crispness or spoilage of the product. The market price varies considerably depending on the size and condition. The larger the jellyfish, the better is the price. Oral arms product has a lower market value than umbrella due to the irregular shape. A premium Grade A jellyfish, with a wholesale price of \$10.00–12.00 per pound in Asia, must be 18 inches in diameter, have a white to creamy colour, and have a crispy texture and be tender at the same time.

*Table 1. Chemical composition, caloric value, and pH of fresh cannonball jellyfish, *Stomolophus meleagris*, desalted ready-to-use (RTU) processed cannonball products, and a RTU commercial Malaysian *Rhopilema* product. Numbers are means (\pm one standard deviation) of 3 determinations from composite samples*

Composition	Fresh cannonball umbrella	RTU Malaysian umbrella	RTU cannonball umbrella	RTU cannonball leg
Moisture (%)	96.10 (0.06)	95.63 (0.01)	95.04 (0.04)	94.08 (0.02)
Ash (%)	1.25 (0.16)	0.69 (0.00)	0.33 (0.00)	0.34 (0.01)
Protein (%)	2.92 (0.04)	4.13 (0.01)	4.69 (0.03)	5.60 (0.02)
Fat (%)	< 0.01	< 0.01	< 0.01	< 0.01
Total (%)	100.27	100.45	100.06	100.02
Cal 100 g ⁻¹	11.68	16.52	17.84	22.4
PH	6.67 (0.01)	4.64 (0.01)	4.46 (0.01)	4.46 (0.01)

The overnight desalting procedure and preparation of jellyfish dish may become a barrier for modern consumers with busy life styles. This has been overcome by developing shredded RTU products with varieties of flavour and sauces. Recently, shredded jellyfish have appeared on the Japanese market packaged together with condiments such as wasabi or

mustard as a convenient ready-to-eat food. Not only are they delectable, but jellyfish are a natural diet food.

Water content of edible jellyfish is about 95% (measured on *Rhopilema esculantum*, Omori, unpublished) and production yield from fresh jellyfish to the marketed commodity is about 7% of the original weight

Nutritional values of jellyfish

We have analyzed the chemical composition of RTU cannonball jellyfish products and compared with that of a commercial Malaysian *Rhopilema* product and a fresh cannonball jellyfish sample. Results of the chemical composition, pH and calculated caloric value per 100 g of serving are shown in Table 1 above⁵.

RTU jellyfish mainly consists of water and protein. They are low in calories, with no detectable crude fat and cholesterol, and trace amounts of sugar. The average moisture content of RTU samples is in a range of 94.1–95.6%. The tissue can bind a large quantity of water; yet maintain a non-watery, crunchy texture. Fresh unprocessed jellyfish are rich in minerals such as Na, Ca, K and Mg, but the processed product is depleted of salts after desalting in fresh water (Hsieh et al., 1996). Salt (NaCl) can be completely removed by soaking in clean water. The hardness of water used and the number of water changes during desalting could affect the residual amount of these elements. However, RTU jellyfish contain a significantly higher amount of aluminum than fresh jellyfish (Hsieh et al., 1996). Apparently, aluminum is contributed from the curing agent, alum and remains in the tissues in a bound form.

Processing time, temperature and the amount of alum used affect the retention of aluminum in jellyfish tissues (unpublished data). In our study, crude fat content in RTU cannonball jellyfish is less than 0.01%. This may be due to the complete removal of mucus and gonads, which contain trace amounts of lipids. According to Hsieh & Rudloe (1994), the cholesterol content of whole fresh jellyfish calculated on a wet weight basis is less than 0.35 mg 100 g⁻¹ based on four species of jellyfish, thus, jellyfish can be declared as a fat-free and cholesterol-free food. Carbohydrate is the other macronutrient that contributes to the caloric value of food. In jellyfish tissue, a trace amount of carbohydrate in the form of sugar is bound to protein as glycoproteins (Kimura et al., 1983). The sum of the percentages of water, lipid, protein, and ash is approximately 100%; therefore, the carbohydrate content in jellyfish is negligible for calorie calculations (Table 1). The calculated caloric value for a normal serving (100 g) of RTU is less than 20 Kcal. Such low caloric value makes jellyfish a natural diet food from the sea.

Protein analysis of salted jellyfish indicates that a Malaysian commercial product and a Chinese product contain an average of 5.5 and 6.8 g of protein per 100 g of salted product, respectively (Huang, 1988). However, the salted product is not the form for consumption. Our results show that percent crude proteins in RTU cannonball jellyfish ranged from 4.7% in umbrellas to 5.6% in legs, values that are higher than the RTU Malaysian commercial product (Table 1). When the combined moisture and ash content increases, protein content decreases. Amino acid analysis shows that tryptophan, a limiting amino acid, is either not detectable or is found in small amounts in jellyfish tissue (Kimura et al., 1983). Thus, the nutritional quality of jellyfish protein quality is low. Glycine accounts for one third of the total amino acid residues with a high proportion of hydroxyproline and hydroxylysine indicating that jellyfish protein is mainly collagen (Barzansky et al., 1975).

⁵ http://www.seaturtle.org/PDF/Hsieh_2001_Hydrobiol.pdf

Species

A few large jellyfish species in the order Rhizostomeae constitute an important food in Chinese cooking. Judging from the type names at market and the external appearance of the semi-dried products, the edible jellyfish harvest in Southeast Asia is composed of more than 8 species. They are caught by various kinds of fishing gear including setnets, drift-nets, hand-nets, scoop-nets, beach-seines and hooks. Some species of large jellyfish are considered to be delicacies for Chinese cooking. Their medicinal value has also been recognized for a long time (South China Sea Institute of Oceanology, 1978; Hsieh & Rudloe, 1994).

- Cepheidae
- *Cephea cephea* (Forskål, 1775)
- Catostylidae
- *Catostylus mosaicus* (Quoy & Gaimard, 1824)
- *Crambione mastigophora* Maas 1903
- *Crambionella orsisi* (Vanhöffen, 1888)
- Lobonematidae
- *Lobonema smithii* Mayer, 1910
- *Lobonemoides gracilis* Light, 1914
- Rhizostomatidae
- *Rhizostoma pulmo* (Macri, 1778)
- *Rhopilema esculentum* Kishinouye, 1891
- *Rhopilema hispidum* (Vanhöffen, 1888)
- *Neopilema nomurai* Kishinouye, 1922
- Stomolophidae
- *Stomolophus meleagris* L. Agassiz, 1862

Edible jellyfish all belong to the order Rhizostomeae, in the Scyphomedusae. The bodies of these jellyfish are large, and considerably tough and rigid, with a thick umbrella. At least 11 species in 5 families, i.e. Cepheidae, Catostylidae, Lobonematidae, Rhizostomatidae and Stomolophidae, are known to be exploited worldwide. Taxonomic characteristics and geographic distribution of each species can be found in Kramp (1961). *Cephea cephea* is distributed widely in the Indo-West Pacific from the Red Sea to Touamotu Archipelago. *Catostylus mosaicus*, *Crambione mastigophora* and *Crambionella orsini* were added rather recently to the list of marketable species. *Catostylus mosaicus* is distributed in the Philippines, New Guinea and west coasts of Australia, and is exploited in New South Wales, Australia. *Crambione mastigophora* occurs in the Malay Archipelago, Java and Truk Island, whereas *Crambionella orsini* is found in the Red Sea, Iranian Gulf and Bengal Bay. *Lobonema smithii* and *Lobonemoides gracilis* are restricted to tropical waters in the Indo-West Pacific. Morphologically these two species are quite similar, and Dr P. Cornelius (pers. comm.) considers that all 'species' of *Lobonema* and *Lobonemoides* to be just one species *Lobonema smithii*. *Rhizostoma pulmo* is distributed in the Mediterranean, Bay of Biscay, North Sea and Black Sea. According to Dr A. Kideys (pers. comm.), a small amount of this species is commercially fished in Turkish coasts of the Sea of Marmara and Black Sea. *Rhopilema esculentum*, the most expensive species at market, is distributed in the western part of Japan, Po Hai, Yellow Sea and the East and South China Sea (Hon et al., 1978). On the other hand, *Rhopilema hispidum* occurs in warmer waters in the Indo-west Pacific, from the southern part of Japan, southern coasts of China, Philippines, Malaysia and Indonesia to the Indian Ocean and the Red Sea. *Stomolophus meleagris* has been recorded in the southeast Atlantic coast of the U.S.A., Gulf of Mexico, off Baja California and off Panama. On the other hand,

Nemopilema nomurai is found in the marginal seas of the northwestern Pacific. This species was described by Kishinouye (1922) as a distinct species, but was mistakenly placed in the genus *Stomolophus* by Uchida (1954), and moreover, it was included under the species *S. meleagris* (Kramp, 1961). However, they are not the same species at all, and we propose to refer *S. nomurai* to its original genus (Omori, Kitamura & Cornelius, unpublished). It grows to an enormous size, being sometimes greater than 1 m in diameter and as much as 150 kg. Heavy occurrence of the species along the Japanese coast of the Sea of Japan was reported in 1920, 1958 and 1995 (Kishinouye, 1922; Shimomura, 1959; Yasuda, 1995). In addition to these 11 species, Dr T. Heeger (pers. comm.) recently informed us that he saw fresh *assiopeandrosia* at the market in Carmen, north of Cebu, Philippines, for local consumption. Because of their large size and difficulties in preservation for taxonomic study, taxonomic specialists have not yet had opportunities to study many specimens of edible jellyfish. Therefore, some species from Southeast Asia have still not been properly identified. Variations in orphological features, size and coloration are considerable, and the taxonomy remains somewhat confused.

Fishing methods

The fishing gear used includes various set-nets, driftnets, push-nets (scoop-nets), hand nets, beach-seines and weirs. A typical set-net with rectangular mouth is set at a depth of 2–10 m across a tidal current. Driftnets are also used across the current flow with a system of floats and sinkers. Hand nets, long poles with two edged iron hooks on top and trawling nets are also commonly used for incidental catch. There is no distinctive difference in fishing methodology applied to different species or locality. In general, the entire body of the Red and Semi-China types are brought back, but for the White and Sand types, fishermen often cut off the ‘leg’ portion (mouth-arms) while at the sea and only umbrellas of the medusae are loaded into the boat.

Fishing is carried out during the daytime only, as fishermen search for jellyfish when they appear at the surface of the water. The main fishing season of jellyfish is between March and May and August and November

Market

Such jellyfish became an important fishery commodity of Southeast Asian countries in the 1970s with increasing demand from the Japanese market. Recently, Japan has imported 5400–10 000 tons of jellyfish products per year, valued at about 25.5 million US dollars, annually from the Philippines, Vietnam, Thailand, Malaysia, Indonesia, Singapore and Myanmar. The fishery is characterized by large fluctuations of the annual catch and a short fishing season that is restricted from two to four months. The average annual catch of jellyfish between 1988 and 1999 in Southeast Asia is estimated to be about 169 000 metric tons in wet weight and the worldwide catch is approximately 321 000 metric tons. In later years the worldwide annual catch has been estimated to ~400 000 metric tons.

Today, the Japanese are the leading consumers of jellyfish. Since the 1970s, with increasing demand from the Japanese market, jellyfish fishing has become popular in Southeast Asia. In Southeast Asia, jellyfish are fished in the Philippines, Vietnam, Malaysia, Thailand, Indonesia, Singapore and Myanmar. One of the present authors (E. N.) has engaged in trade of jellyfish commodity for 27 years. He estimates that about two thirds of the products are exported to Japan and the remainders are sold to South Korea, Taiwan, Singapore, Hong Kong and recently the U.S.A.

According to records of the Tokyo Customs House, the amount of semi-dried jellyfish commodities imported annually from Southeast Asia to Japan varied from 5369 to 10 084 metric tons (average 7874 tons per year) during the period from 1988 to 1999. As the total amount imported from China during the same 12-year period averaged 2933 tons, the figures show the current importance of jellyfish production in Southeast Asia. A number of dealers and merchants estimate that the actual catch of jellyfish in Southeast Asia may be approximately 1.5 times larger than the amount exported to Japan. The commercial value of imported commodities from Southeast Asia to Japan varied annually from 1479 to 4113 million JPN yen (average 2733 JPN yen which is equivalent to about 25.5 million US dollars) between 1988 and 1999. This figure is only slightly higher than the total value of jellyfish imported from China, because the Chinese commodity consisted mainly of the most favored species, *Rhopilema esculentum*. In this connection, the price of the umbrella of *R. esculentum* is about 2400 JPN yen kg⁻¹, whereas that of whole Southeast Asian (mixed) species is only about 350 JPN yen kg⁻¹. The price of the mouth-arms is generally less than half that of the umbrella portion.

Rhopilema esculenta Shandong Wang Er Zhuang Jellyfish Wholesale Market:

21(high) 14(low) 17(avg) RMB/kg dato 2007-8-21 RMB= 0,132\$

Gives an average price of 2,24\$/kg

Importers China

[Dandong Sea-Gull Seafood Company](#)

CHINA - one of the biggest frozen seafood and salted seafood importer in china. the category imported is salted jelly fish, ribbon fish, yellow croaker, T.T. croaker and silver croaker, cuttle fish and so on.

[Huatong Seafood Co. Ltd](#)

CHINA - We import salted jellyfish. We can also provide technical support for processing.

[Jiaojiang Import and Export Co. Ltd](#)

CHINA - frozen seafood and salted seafood importer in china. the category imported is salted jelly fish, ribbon fish, yellow croaker, T.T. croaker and silver croaker, cuttle fish.

[Meetal Foods Co. Ltd](#)

CHINA - Importers, Exporters, Producers and wholesalers illex squid, giant squid, king crab, salted jellyfish, sea cucumber, fish, pollock, hake, redfish, saithe, cod, salmon, greenland halibut, mackerel, scallop, oyster, clam meat

3.6 Collagen

Collagen is the main protein of connective tissue in animals and the most abundant protein in mammals, making up about 25% to 35% of the whole-body protein content. It is naturally found exclusively in metazoa, including sponges. In muscle tissue it serves as a major component of endomysium. Collagen constitutes 1% to 2% of muscle tissue, and accounts for

6% of the weight of strong, tendinous muscles. The gelatin used in food and industry is derived from the partial hydrolysis of collagen.

Collagen is one of the long, fibrous structural proteins whose functions are quite different from those of globular proteins such as enzymes. Tough bundles of collagen called collagen fibers are a major component of the extracellular matrix that supports most tissues and gives cells structure from the outside, but collagen is also found inside certain cells. Collagen has great tensile strength, and is the main component of fascia, cartilage, ligaments, tendons, bone and skin. Along with soft keratin, it is responsible for skin strength and elasticity, and its degradation leads to wrinkles that accompany aging. It strengthens blood vessels and plays a role in tissue development. It is present in the cornea and lens of the eye in crystalline form. It is also used in cosmetic surgery and burns surgery. Hydrolyzed collagen can play an important role in weight management, as a protein, it can be advantageously used for its satiating power.

Types and associated disorders

Collagen occurs in many places throughout the body. The 29 types of collagen have thus far been identified and described in literature. Over 90% of the collagen in the body, however, are of type I, II, III, and IV.

- Collagen One: skin, tendon, vascular, ligature, organs, bone (main component of bone)
- Collagen Two: cartilage (main component of cartilage)
- Collagen Three: reticulate (main component of reticular fibers), commonly found alongside type I.
- Collagen Four: forms bases of cell basement membrane

Applications of collagen

Industrial uses

If collagen is sufficiently denatured, e.g. by heating, the three tropocollagen strands separate partially or completely into globular domains, containing a different secondary structure to the normal collagen polyproline II (PPII), e.g. random coils. This process describes the formation of gelatin, which is used in many foods, including flavored gelatin desserts. Besides food, gelatin has been used in pharmaceutical, cosmetic, and photography industries. From a nutritional point of view, collagen and gelatin are a poor-quality sole source of protein since they do not contain all the essential amino acids in the proportions that the human body requires—they are not 'complete proteins' (as defined by food science, not that they are partially structured)⁶. Manufacturers of collagen-based dietary supplements claim that their products can improve skin and fingernail quality as well as joint health. However, mainstream scientific research has not shown strong evidence to support these claims. Individuals with problems in these areas are more likely to be suffering from some other underlying condition (such as normal aging, dry skin, arthritis etc.) rather than just a protein deficiency.

From the Greek for glue, kolla, the word collagen means "glue producer" and refers to the early process of boiling the skin and sinews of horses and other animals to obtain glue. Collagen adhesive was used by Egyptians about 4,000 years ago, and Native Americans used

⁶ <http://en.wikipedia.org/wiki/Collagen>

it in bows about 1,500 years ago. The oldest glue in the world, carbon-dated as more than 8,000 years old, was found to be collagen—used as a protective lining on rope baskets and embroidered fabrics, and to hold utensils together; also in crisscross decorations on human skulls. Collagen normally converts to gelatin, but survived due to the dry conditions. Animal glues are thermoplastic, softening again upon reheating, and so they are still used in making musical instruments such as fine violins and guitars, which may have to be reopened for repairs—an application incompatible with tough, synthetic plastic adhesives, which are permanent. Animal sinews and skins, including leather, have been used to make useful articles for millennia.

Gelatin-resorcinol-formaldehyde glue (and with formaldehyde replaced by less-toxic pentanediol and ethanediol) has been used to repair experimental incisions in rabbit lungs.

Medical uses

Collagen has been widely used in cosmetic surgery, as a healing aid for burn patients for reconstruction of bone and a wide variety of dental, orthopedic and surgical purposes⁷. Some points of interest are:

1. when used cosmetically, there is a chance of allergic reactions causing prolonged redness; however, this can be virtually eliminated by simple and inconspicuous patch testing prior to cosmetic use, and
2. most medical collagen is derived from young beef cattle (bovine) from certified BSE (Bovine spongiform encephalopathy) free animals. Most manufacturers use donor animals from either "closed herds", or from countries which have never had a reported case of BSE such as Australia, Brazil and New Zealand. Lately the restrictions on the use of bovine collagen has been lifted in most countries (Nofima 2010)
3. porcine (pig) tissue is also widely used for producing collagen sheet for a variety of surgical purposes.
4. alternatives using the patient's own fat, hyaluronic acid or polyacrylamide gel are readily available.

Collagens are widely employed in the construction of artificial skin substitutes used in the management of severe burns. These collagens may be derived from bovine, equine or porcine, and even human, sources and are sometimes used in combination with silicones, glycosaminoglycans, fibroblasts, growth factors and other substances.

Collagen is also sold commercially as a joint mobility supplement. Because proteins are broken down into amino acids before absorption, there is no reason for orally ingested collagen to affect connective tissue in the body, except through the effect of individual amino acid supplementation.

Recently an alternative to animal-derived collagen has become available. Although expensive, this human collagen, derived from donor cadavers, placentas and aborted fetuses, may minimize the possibility of immune reactions.

Although it cannot be absorbed through the skin, collagen is now being used as a main ingredient for some cosmetic makeup.

⁷ <http://en.wikipedia.org/wiki/Collagen>

Collagen in jellyfish

Being a marine creature, jellyfish has never been exposed to BSE, and thus considered “safe”. One other aspect is that collagen from jellyfish might appeal to vegetarians and vegans who need protein supplement and might shun protein sources from land mammals. The mesogloea collagen of a primitive animal, the jellyfish *Stomolophus nomurai*, belonging to the class Scyphozoa in the Coelenterata, was studied with respect to its chain structure. Most of the mesogloea collagen was solubilized by limited digestion with pepsin and isolated by selective precipitation at 0.9 M NaCl in 0.5 M acetic acid. Upon denaturation, the pepsin-solubilized collagen produced three distinct α chains, $\alpha 1$, $\alpha 2$, and $\alpha 3$, in comparable amounts which were separable by CM-cellulose chromatography. The nonidentity of these α chains was confirmed by amino acid and carbohydrate analyses and peptide mapping. Furthermore, the introduction of intramolecular crosslinks into native molecules by formaldehyde yielded a large proportion of γ_{123} chain with chain structure $\alpha 1, \alpha 2, \alpha 3$, as judged by chromatographic behavior and peptide maps. We concluded that mesogloea collagen is comprised of $\alpha 1\alpha 2\alpha 3$ heterotrimers and is chemically like vertebrate Type V collagen⁸.

As part of a continuing program to obtain phylogenetic data, collagen from the mesogloea tissue of the jellyfish *Stomolophus nomurai*, belonging to the Coelenterata, was studied with respect to its chain structure. This large edible jellyfish has well-developed mesogloea tissue, and recently more than 60% of the tissue components were found to be collagen rich in hydroxylysine-linked carbohydrate

Mesogloea collagen consists of $\alpha 1\alpha 2\alpha 3$ molecules containing three distinct subunits.

The jellyfish mesogloea contained a small amount of acid-soluble protein; the yields of collagen and noncollagenous protein were only 2.2 and 1.4%, respectively, on the basis of washed dry weight. Amino acid analyses suggest that the overall patterns indicative of collagen rich in hydroxylysine-linked carbohydrates are common to both soluble and pepsin-solubilized collagen fractions (Table I), while the contamination by non-collagenous protein in the former fraction is apparent from the relatively low content of glycine (309 residues/1000).

⁸ <http://www.jbc.org/content/279/46/47711.full>

TABLE I
Amino acid and carbohydrate composition of protein fractions derived from jellyfish mesogloea

	Acid-soluble proteins		Pepsin-solubilized collagen
	Collagen	Noncollagenous protein	
	<i>residues/1000</i>		
3-Hydroxyproline	1	0	3
4-Hydroxyproline	45	7	54
Aspartic acid	78	98	71
Threonine	31	55	28
Serine	47	75	45
Glutamic acid	98	101	94
Proline	74	52	79
Glycine	309	133	344
Alanine	78	71	77
Half-cystine	6	33	0
Valine	31	58	24
Methionine	7	11	8
Isoleucine	21	37	16
Leucine	32	58	27
Tyrosine	9	27	5
Phenylalanine	12	31	8
Tryptophan	1	14	0
Hydroxylysine	30	5	35
Lysine	32	68	24
Histidine	6	13	1
Arginine	52	53	57
Totals	1000	1000	1000
Glucosylgalactosyl-hydroxylysine	19		24
Galactosylhydroxylysine	1		0

A type of jellyfish usually considered a nuisance may become useful in the cosmetics and pharmaceutical fields due to a new technique that extracts collagen from the creature.

In a process developed by Fukui Prefectural University and other institutions, collagen has been extracted from mizukurage, or moon jellyfish. But the technology can be applied to other jellyfish species such as the infamous Nomura's jellyfish, also known as Echizen jellyfish, according to the institutions. Normally, collagen is extracted from the skin of fish or

pigs. Other research projects have reached similar results in extracting collagen from jellyfish (SINTEF 2010).

Moon jellyfish have a diameter of between 15 to 30 centimeters. In summer, the jellyfish proliferate in swimming areas near beaches.

The company asked Reiji Yoshinaka, professor emeritus at the university, Yoshihiro Yokoyama, professor at the university, and others to conduct research on possible ways to deal with the jellyfish in 2003.

According to Shoshi Mizuta, an associate professor at the university and a member of the research team, the jellyfish decomposes when kept at low temperatures for a certain period of time.

The researchers found that several enzymes played a role in inducing this phenomenon when the water temperature dropped to around 4 C.

Collagen fibers, which are in the jellyfish's body structure, were successfully isolated and purified from the liquefied jellyfish.

According to the team, 1 kilogram of the jellyfish contains 1 gram of collagen, and has less odor compared to collagen extracted from pigs or fish.

Until around 2005, the team came close but fell short of successfully extracting jellyfish collagen. [Technoble Co.](#), a Nishi Ward, Osaka-based cosmetics material supplier, took note of the team's earlier research results and conducted its own experiments to develop the technology with the team's approval. Since then, the firm has built a facility to produce large quantities of collagen of high purity. "We're very happy that our research to make use of the troublesome jellyfish led to a good result. We hope the technology will be commercialized soon," Mizuta said in July 2009. As of 2010, it has not yet been fully commercialized.

Market

The collagen market is worldwide. The uses and price of collagen depends on the quality of the product; refining, colour, taste and smell to mention a few. One other major factor is the amino acid profile of the collagen in question. The amino acid profile determines what uses the collagen has, and largely the value. Collagen from jellyfish is available on the market today at varying prices. Some samples are given under:

Fish collagen:

Processed powder small doses for eating: 11\$/kg⁹

Processed powder small doses for eating: 10-20\$/kg¹⁰

Jellyfish collagen:

Processed powder small doses for eating: 10\$/kg¹¹

⁹ http://www.diytrade.com/china/4/products-list/0-k-c-1/fish_collagen.html

¹⁰ <http://johson-gogo.en.made-in-china.com/product/TeOxhWsAniko/China-Edible-Fish-Collagen-Powder-for-Food-Cosmetic.html>

¹¹ <http://www.made-in-china.com/showroom/jellyfishcollagen/product-detailAbwQtFRjsakl/China-Jellyfish-Collagen-Peptide-Powder-LTMBTJC0707-01-.html>

Fish bones and fish skin is the dominating source for harvesting collagen. The amount of collagen in these sources varies, but typically 40-50%¹². Being relatively available in large quantities for 0.1 \$ pr kilo¹³, it sets the limit on the value of jellyfish as collagen source.

3.7 Fish/marine animal feed

The main part of the dry matter in jellyfish is collagen which is one of the important ingredients in fish feed. Collagen (protein) have some distinct characteristics that need to meet certain requirements in order to make it useful for fish feed production. One of the most important is the amino acid profile, and it often decides the value of the given protein. The amino acid profile sets barriers on what other ingredients can be mixed in the fish feed and the nutrition value of the protein. From a nutritional point of view, collagen and gelatin are a poor-quality sole source of protein since they do not contain all the essential amino acids in the proportions that the human body requires. In particular are the producers cautious on the nitrogen producing aspect. In general they want to use substances that emit low levels of nitrogen.

Another key value of the protein source is the level of minerals and heavy metals that can produce unwanted effects in the fish feed. This is a commonly known problem, but can be solved by refining the product. However this comes at an additional cost, and the values of unwanted minerals and heavy metals in jellyfish from different areas is not known.

The third major factor is the acceptance rate of the fish, in other words will the fish eat the feed. Taste is a very important issue, as some species are very picky on what they will eat. The protein and the corresponding amino acids are the main contributors to how the feed taste.

In order to be a reliable source for the production of fishfeed, a jellyfish source need to be stable and readily available in large quantities.

The major protein source in todays fish feed production is fishmeal, and it usually contributes to 25-30% of the ingredients of stock fish feed. Depending on the seasonal and yearly availability, the fish feed producers use varying amounts of fishmeal in their production. Other sources are waste product from agricultural production, such as corn and wheat, but also beans and sunflowers are widely used as a protein source. The protein sources are very interchangeable; the producers choose the protein source based on availability and price. The protein content of the source has small variations, typically around 60-65% for plant substances and 68-70% in fishmeal. Depending on protein content and availability of the source, a price range of 700-1500\$ pr metric ton is normal (source NOFIMA).

As of today, none of the fish feed producers in Norway (such as EWOS and Skretting) have participated in, or are interested in researching the possibility of using jellyfish as a source for protein. Nofima are aware on the possibility, but have not done any research on the field. The main feedback is that protein is readily available in large quantities from waste products in the agricultural industry, when the fish meal is scarce. With the European ban lifted on the use of

¹² Laboratory of Marine Biochemistry, Faculty of Agriculture, Kyushu University, Fukuoka 812-8581, Japan

¹³ <http://fis.com/fis/techno/newtechno.asp?id=35254&l=e&ndb=1>

waste product from the land based industry (bonemeal from bovine/poultry), the access to high grade protein is even better than before.

There are some conflicting information in regards to the level of collagen in jellyfish. However several reports gives the approximate collagen content in the umbrella and oral arm was 0.12 and 0.09 % of wet tissue, which is considerably low value when compared with the muscle tissues of other invertebrate animals (Mizuta et al., 1994a; Mizuta et al., 1994b; Mizuta et al., 2004). And thus one ton of jellyfish collagen corresponds to approximately $(1/0,001) = 1000$ tons raw jellyfish. With the current prices on protein for fish feed, one can assume that land processing is too costly and that processing is needed onboard, since the average fishing vessel in question will rarely have a capacity over 500 tonnes, and transporting unprocessed jellyfish that contain a lot of water is not an option.

Market:

The major fishfeed consumers are Norway, Chile, Canada, Scotland and China. As of 2009 the global market for fish feed was ~70 million tonnes. There is little “loyalty” to what resource fish feed producers use as collagen source (as long as the amino acid profile is correct), as new technology and research have made the different sources interchangeable (for example can producers easily switch between fish meal and soya as protein source (Nofima 2010)). As the main ingredient in fishfeed typically contains 65% collagen, the value of jellyfish collagen as feed will be dictated from the price of fish feed.

Raw material for fish feed production (fish meal, soy etc): 700-1500\$ pr ton.

3.8 Medical

Medicinal value of jellyfish Jellyfish have long been recognized for medicinal value (Omori, 1981; Hsieh & Rudloe, 1994). It is believed to be an effective cure for arthritis, hypertension, back pain and ulcers, while softening skin and improving digestion. Jellyfish is also alleged to remedy fatigue and exhaustion, stimulate blood flow during the menstrual cycle of women, and ease any type of swelling. Most of these claims regarding the medicinal value of jellyfish are described in non-scientific publications in Chinese. In Korea, jellyfish are promoted on television and in womens magazines as an aid for weight loss and beautiful skin. Australian aboriginal shamans have prescribed dried jellyfish powder as a treatment for burns (Hsieh & Rudloe, 1994). However, no scientific research has been carried out to document the medicinal efficacy of jellyfish. Collagen has been hypothesized to be the ingredient in jellyfish contributing to the beneficial health effects because collagen is the essential building material of muscle tissue, cartilage and bone, and has a great medicinal promise (Hsieh & Rudloe, 1994).

Effect on arthritis

Recently, we conducted a small scale animal study investigating the health effect of jellyfish collagen on arthritis in rats. Laboratory rats were divided equally into 5 experimental groups with 5 animals in each group. Three groups were fed daily with 10 µg of jellyfish collagen per rat for 6 days before, after, and before and after injection of the arthritis inducing reagent, bovine type II collagen (Wood et al., 1969). A positive control group was induced with arthritis without collagen treatment and a negative control group consisted of normal healthy rats. All animals were examined daily for joint thickness and swelling to evaluate the onset

and severity of the disease. An arthritis score was derived by grading the severity of involvement of each paw from 0 to 4 (0=normal, 1=redness, 2=redness plus mild swelling, 3=severe swelling, 4=joint deformity) according to Trentham et al. (1977). Delayed-type hypersensitivity and serum anti-CII antibody levels were also monitored according to Yoshino et al. (1995). The average onset of arthritis in the positive control group was 19 days after induction of the disease, while in the jellyfish-fed groups was delayed to 24–29 days. The average arthritis scores for all jellyfish fed groups were lower than the positive control group. Our results demonstrated that laboratory rats fed with lowdoses of jellyfish collagen had significantly ($p < 0.05$) reduced incidence, onset and severity of antigen-induced arthritis, a model that shares clinical, histological, immunological and genetic features with human rheumatoid arthritis. Detailed methods and complete results of the study will be published elsewhere.

Artificial skin

Skin, the human body's largest organ, protects the body from disease and physical damage, and helps to regulate body temperature. It is composed of two major layers, the epidermis and the dermis. The epidermis, or outer, layer is composed primarily of cells: keratinocytes, melanocytes, and langerhans. The dermis, composed primarily of connective tissue fibers such as collagen, supplies nourishment to the epidermis. When the skin has been seriously damaged through disease or burns, the body cannot act fast enough to manufacture the necessary replacement cells. Wounds, such as skin ulcers suffered by diabetics, may not heal and limbs must be amputated. Burn victims may die from infection and the loss of plasma. Skin grafts were developed as a way to prevent such consequences as well as to correct deformities. As early as the sixth century B.C., Hindu surgeons were involved in nose reconstruction, grafting skin flaps from the patient's nose. Gaspare Tagliacozzo, an Italian physician, brought the technique to Western medicine in the sixteenth century.

Until the late twentieth century, skin grafts were constructed from the patient's own skin (autografts) or cadaver skin (allografts). Infection or, in the case of cadaver skin, rejection were primary concerns. While skin grafted from one part of a patient's body to another is immune to rejection, skin grafts from a donor to a recipient are rejected more aggressively than any other tissue graft or transplant. Although cadaver skin can provide protection from infection and loss of fluids during a burn victim's initial healing period, a subsequent graft of the patient's own skin is often required. The physician is restricted to what skin the patient has available, a decided disadvantage in the case of severe burn victims.

In the mid-1980s, medical researchers and chemical engineers, working in the fields of cell biology and plastics manufacturing, joined forces to develop tissue engineering to reduce the incidences of infection and rejection. One of the catalysts for tissue engineering was the growing shortage of organs available for transplantation. The first step was to duplicate the body's production of tissue. Langer came up with the idea of constructing a biodegradable scaffolding on which skin cells could be grown using fibroblasts.

In a variation of this technique developed by other researchers, the extracted fibroblasts are added to collagen, a fibrous protein found in connective tissue. When the compound is heated, the collagen gels and traps the fibroblasts, which in turn arrange themselves around the collagen, becoming compact, dense, and fibrous. After several weeks, keratinocytes, also extracted from the donated foreskins, are seeded onto the new dermal tissue, where they create an epidermal layer.

An artificial skin graft offers several advantages over those derived from the patient and cadavers. It eliminates the need for tissue typing. Artificial skin can be made in large quantities and frozen for storage and shipping, making it available as needed. Each culture is screened for pathogens, severely curtailing the chance of infection. Because artificial skin does not contain immunogenic cells such as dendritic cells and capillary endothelial cells, it is not rejected by the body. Finally, rehabilitation time is significantly reduced.

The Manufacturing Process

The manufacturing process is deceptively simple. Its main function is to trick the extracted fibroblasts into believing that they are in the human body so that they communicate with each other in the natural way to create new skin.

- Cells are transferred to a culture system. A small amount of the cold collagen and nutrient media, approximately 12% of the combined solution, is added to the fibroblasts. The mixture is dispensed into molds and allowed to come to room temperature. As the collagen warms, it gels, trapping the fibroblasts and generating the growth of new skin cells.
- Keratinocytes added. Two weeks after the collagen is added to the fibroblasts, the extracted keratinocytes are thawed and seeded onto the new dermal skin. They are allowed to grow for several days and then exposed to air, inducing the keratinocytes to form epidermal layers.
- Growth cycle completed. The new skin is stored in sterile containers until needed.

Future applications

The medical profession is using artificial skin technology to pioneer organ reconstruction. It is hoped that this so-called engineered structural tissue will, for example, someday replace plastic and metal prostheses currently used to replace damaged joints and bones. Ears and noses will be reconstructed by seeding cartilage cells on polymer mesh. The regeneration of breast and urethral tissues is currently under study in the laboratory. Through this technology, it is possible that one day, livers, kidneys, and even hearts, will be grown from human tissues.

Market

The developed market for medical purposes is mainly correlated to the artificial skin, since the research on and effect on arthritis and other applications is relatively new. The market for artificial skin is expected to rise in the years to come as the various conflicts in the world raises the demand for treatment of burn injuries. One report estimates the global market evaluations estimate that the medical aspect of collagen production has a potential for annual revenue greater than \$30 billion. We have not been able to give sample prices for these products as they vary extremely related to refining and areas of applications, but this is typically very high tech and high cost products. In order to be applicable for these uses the collagen needs to be of extremely high quality, and can only be obtained through close cooperation with artificial skin manufacturers.

6. Market scan

As Asia is a key region in regards to jellyfish as they are the main producers and consumers of jellyfish products. It is the region that has most problems with jellyfish, but also the region that utilize the jellyfish in numerous ways. Through cooperation with Innovation Norway, we have sought specific market knowledge on the Asian market, represented by South Korea, China and Japan. Below are the key findings in the respective countries.

3.9 Korea

The National Fisheries Research and Development Institute (NFRDI), a government R&D institute in marine area, reported that out of the world's 350 known jellyfish species, 20 to 30 of them have been spotted in the Southern and Yellow seas in Korea. Major species that found in the Korean coastal area:

- *Turritopsis nutricula*
- *Cladonema radiatum*
- *Eirene menoni*
- *Gonionemus vertens*
- *Craspedacusta sowerbii*
- *Rathkea octapunctata*
- *Spirocodon saltatrix*
- *Dipleurosoma typicum*
- *Stenoscyphus inabai*
- *Aurelia aurita* (most common)
- *Nemopilema nomurai* (most common)

Aurelia aurita is getting into the sea of Korea and Japan with sea currents from the Eastern seashore of China, its size is about 30 cm. Appears in contaminated areas the whole year, showing higher number especially between April and August. Although having no toxicity, it causes indirect damage such as inflow into power stations and inconvenience to the fishing vessel.

Nemopilema nomurai, or Nomura jellyfish, make up the majority of the population and are one of the largest types of jellyfish in Korea. They can grow up to 2 m in diameter and weigh up to 220 kg. It has tentacles of toxicity and preys on young fish. This jelly fish is very poisonous and usually appears in the southern sea and does harm to summer visitors and fisheries.

A growing number of harmful Nomura jellyfish have been spotted on the Korean coast and are frustrating fishermen, who are complaining of a reduction in fish they catch.

The population is on the rise in the fishing waters and is a serious problem to the fishermen because a large number of the Nomura's jellyfish get caught in their nets. With the increase in the jellyfish population, labour has increased along with a decrease in profits and damaged nets. Nets often break from the added weight of the unwanted prey, which can also bruise or kill fish. Overall, the jellyfish have hurt profits and led to extra labour needed to remove them from fishing nets.

In addition, jelly fish blocks intake of atomic power stations where cooling water flows into, which often stops their operations.

The massive appearance of jelly fish has been recently observed and the reasons for this are presumed as follows:

1) Over fishing

The remarkable development of fishing gear and high demands for seafood have contributed to the decrease in fish resources. It means the reduction of predators which prey on jelly fish, which in turn increases the number of jelly fish under the environment of no harsh competition for foods.

2) Increase in water temperature

The sudden jellyfish overpopulation has been attributed to rising global ocean temperatures. Most jelly fish likes warm water. The ongoing global warming has helped them to live longer and extend their territory to colder ocean even in winter season.

3) Increase in artificial structures

In the development process of jelly fish, polyp lives by sticking to base rocks or water structures, and in this stage new polyps are much produced. That means water structures set up around harbours or bridges construction sites are served as a proper place for polyp.

Korean Ocean Research Development Institute (KORDI):

- Long and mid-term atomic research & development project of the Ministry of Science and Technology. Research on “Technology to prevent marine life from blocking intake”
- Developed technology that can eliminate a massive life inflowing into intake by Korea Hydro & Nuclear Power Co.
Outcomes: development of prototype high-speed screen and completed its performance on actual spots.

On a governmental level the NFRDI Jellyfish Monitoring Center – a government-led monitoring programme which purpose is to build up a monitoring system that shares information of jelly fish for comprehensive and systematic measures. The idea is monitoring through the cooperation of fishermen and their local governments. It will then provide information to fishermen after collection and analysis of monitored documents through homepage/telephone/fax every week with special urgent notifications of toxic jelly fish and for the selection of fishing-operable areas.

Through this system the government aims to prevent damage through developing a model that can predict the movement of jelly fish. NFRDI and KORDI has plans to develop device of low cost and high efficiency that can stop a massive inflow of jelly fish. (NFRDI is experimenting such device and KORDI has completed the development and finished its verification).

Furthermore, there have been established an international cooperation forum which purpose is to seek international cooperation on higher efficiency of jelly fish research. The following cooperation institutions are participating:

Korea: NFRDI

China: East China Sea Fisheries Research Institute

Japan: Fisheries Research Agency

For the time being they have agreed upon a MOU agreement between fishery research institutes of Korea, China and Japan to:

- (1) Sharing joint research document: monitoring and analysis document of the appearance of jelly fish
- (2) Carrying out joint research: Korea, China and Japan have little reliable documents of main place of origin of poisonous Nomurai jelly fish, which requires a joint research
- (3) Holding symposium

In the future there exist plans to broaden the cooperation to include academic joint research on the level of university.

NFRDI is working on a comprehensive national program to cut the jellyfish numbers, including the removal and utilization of by-products, for cosmetics and pharmaceuticals.

A fishing net specially designed to efficiently remove unwanted jellyfish was developed by NFRDI and is being tested on fishing boats in Korea.

A public demonstration was held to explain the functions of the net, which has three different stainless steel wiring grids inside, which slice and kill larger jellyfish while allowing other catch to pass through. The device is capable of eliminating more than 1 ton of jelly fish per hour (elimination effect 80%), while allowing fishermen to continue fishing. There is no mentioning of the possible problem with increased release of eggs when killing jellyfish this way.

KORDI developed jelly fish destructor, high-speed screen device.

- Use: to prevent the block of intake of nuclear power plants
- Composition of high-speed screen device: floating device, re-floating device, discharge device
- Floating jelly fish and other species by the use of bubble (=floating device)
- Then, re-floating them through Brush screen (=re-floating device)
- And separating from brush and then sending them to the edge of a net (=discharge device)
- Performance test result: eliminated more than 95% of jelly fish



Korea has been harvesting the jellyfish as much as possible. They use collagen from the jellyfish in cosmetic products, and the government is encouraging more public consumption. NFRDI developed a device that eliminates water from jelly fish that makes it possible to extract collagen for cosmetics and DHA, EPA unsaturated fatty acids which are used for anti-cancer medicine and antioxidant.

Furthermore NFRDI claims that minced jelly fish could become an effective feed for younger fish at fish farm site.

Consumption of jellyfish as food has not been advocated in Korea because Nomura jellyfish have a high toxicity level and a strong flavor, which is difficult to market, a government official said, instead, jellyfish for consumption in South Korea are largely imported.

It is reported that 5,450 tons (=US\$ 10 million) of imports in 2008 were brought in from countries such as China (45%), Thailand (34%), Indonesia (12%) and Vietnam (8%).

Korean citizens eat 4 species of jelly fish as food mainly because the rest of the species causes rash on skin and is poisonous.

Summary

It has been reported that a massive appearance of jelly fish does severe harm to fishermen.

Korea Ministry of Food, Agriculture, Forestry and Fisheries has positively supported the research on the elimination of jelly fish and for the development of device for it.

The government run research institute NFRDI and KORDI already developed jelly fish destructor that will be commercialized soon. Along with this, some groups of fishermen are developing and using similar device themselves.

A jelly fish destructor developed jointly by the government and fishermen is now in the test and the result is very satisfactory.

3.10 Japan

Japan is the country where fishing has been hit the hardest by the increasing population of jellyfish. The Japanese government has tried several methods of getting rid of the jellyfish invasion.

Destruction of jellyfish is funded by Japanese government and is operated by fishermen. They already have a technology and are using it for the destruction of jellyfish in Japan. Although there are no intention to block devices or suggestion of any foreign technology, the barrier is perceived as high. This mainly due to the difference in the fishing methods and size of fishing vessels from other countries. Typically, Japanese fishing vessels are slim, long stretched and shallow, while Norwegian vessels are broad, short and deep. Japan would approve a technology only when it was proven effective on the actual Japanese fishery practice. There might be a possibility to introduce COJECT on local Japanese fisheries, but it is probably necessary to cooperate with equipment suppliers in Japan such as Nitto Seimo (Net company) to gain access to the market, due to the requirement for test data to be qualified:

- National Federation of Fisheries Co-operative Associations (JF Zengyoren) is the coordinator of the funding. It formed a committee to counteract the Jellyfish problem and this committee evaluates different types of technology developed by equipment producers.
- To be approved as a new technology, one must go through the evaluation by the committee. It requires the test data collected at coastal of Japan, in order for them to compare the fishing result with/without the technology.

Examples of existing technology on the Japanese market:

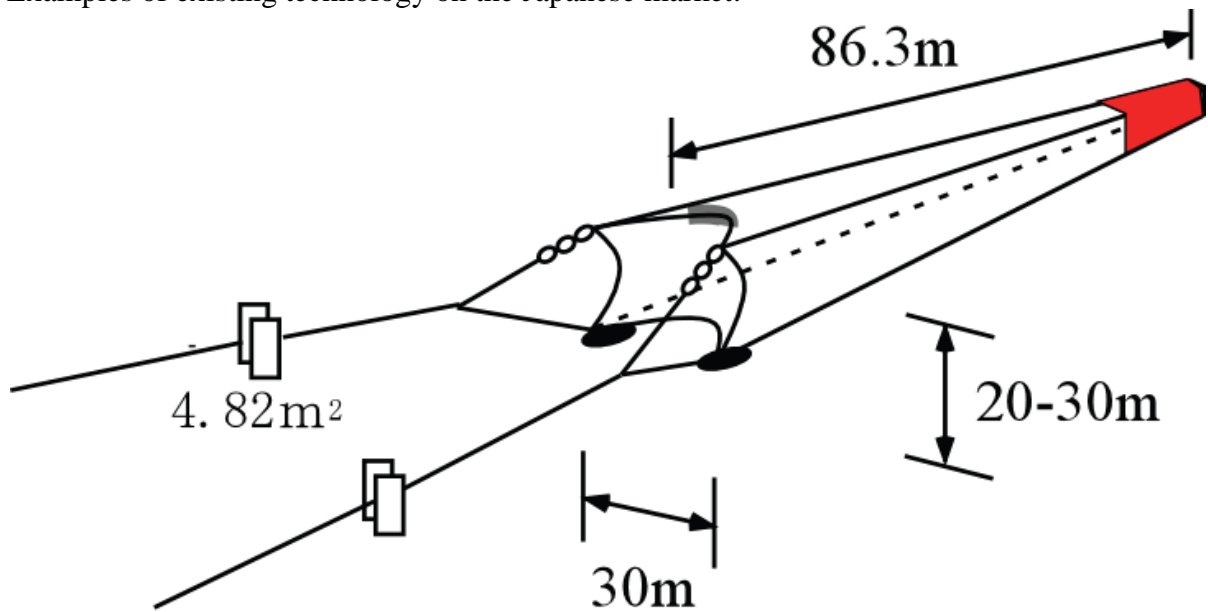

Top 2 are the research, bottom one is for the destruction trawl.

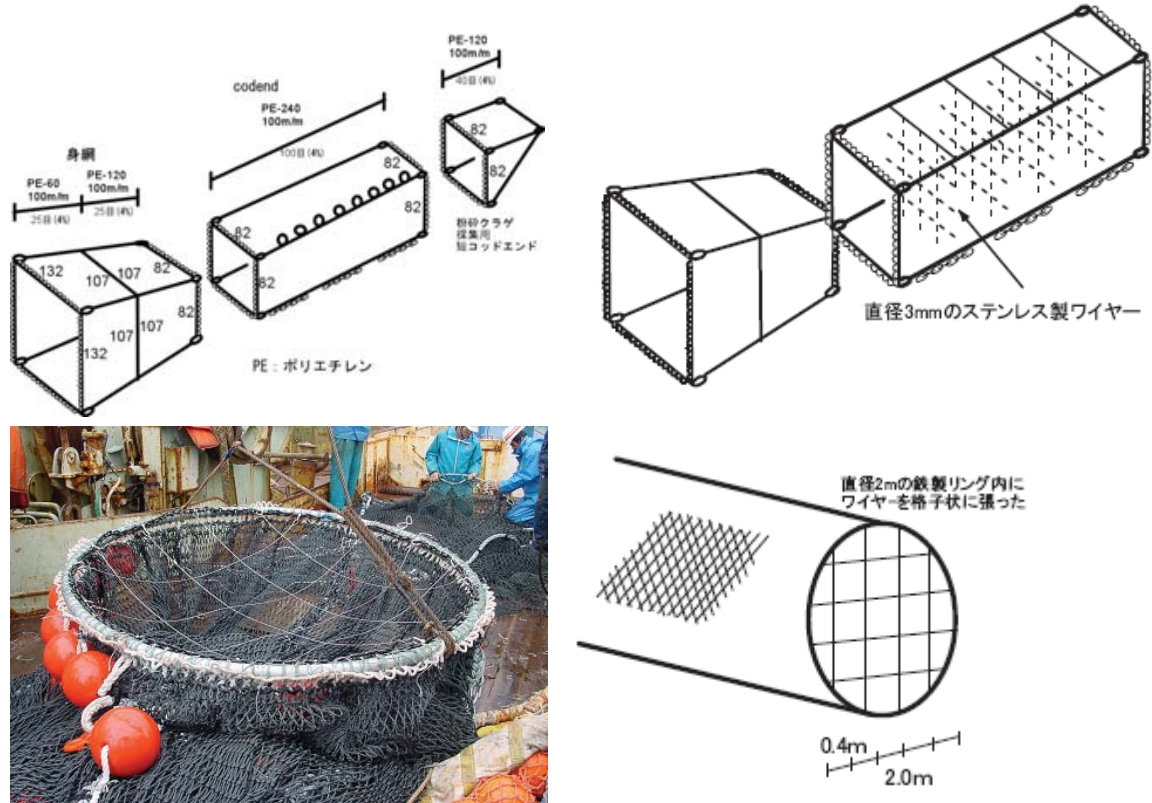

Destruction of jellyfish at Fixed net (Set net) site. Combination of pump and propeller:



As much as putting an effort into destroying jellyfish caught by the fishing equipment, an even bigger effort are put into preventing jellyfish from entering the fishing equipment in the first place, since fishermen have to keep fishing to gain income. Separation trawls:

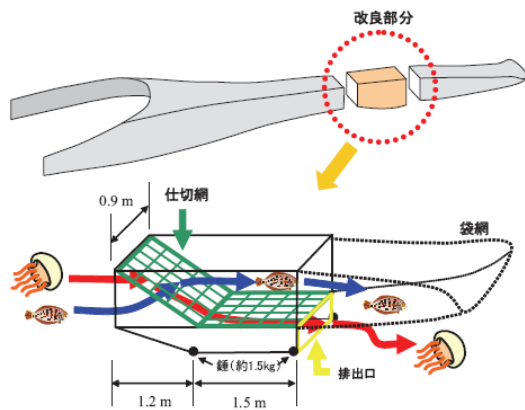
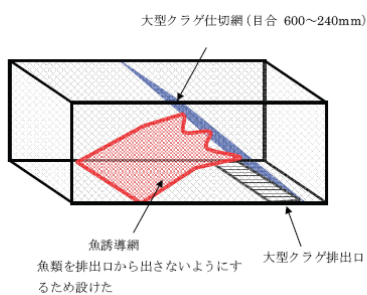
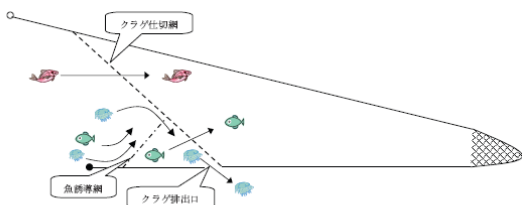
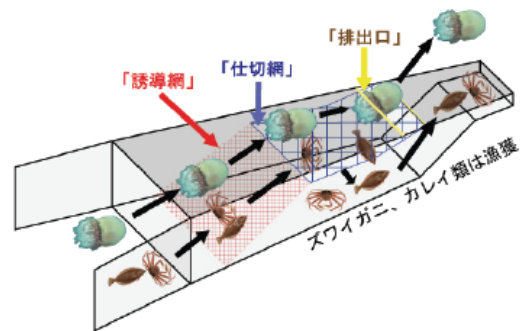
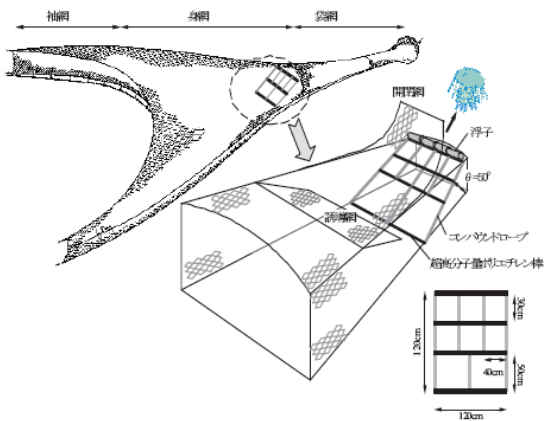
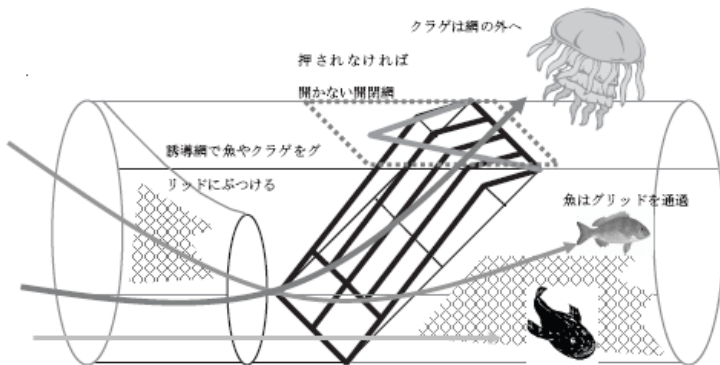
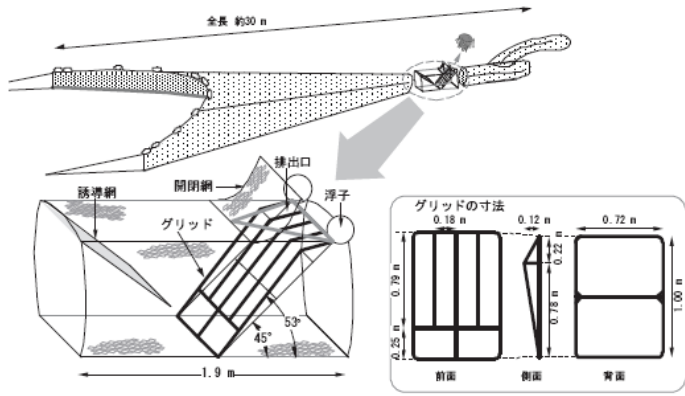

Separation of jellyfish by fixed nets:

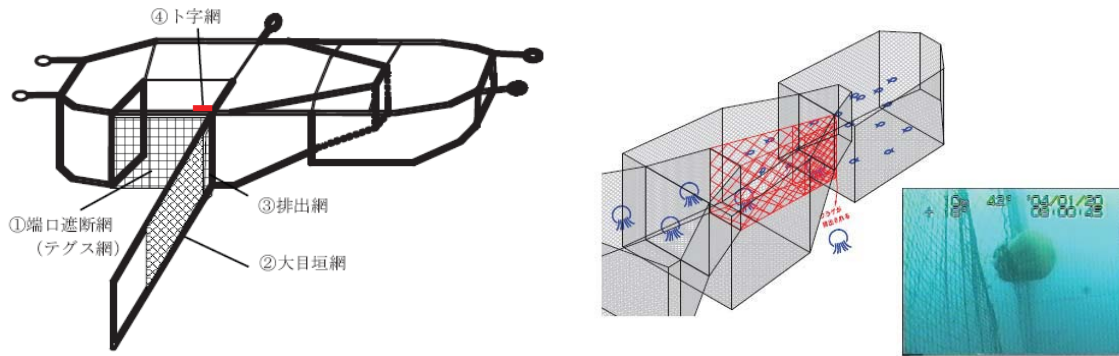

Jellyfish is commonly used as food in Japan. According to the study made by the Fisheries Research Agency, there are 3 main species of jellyfish used as food:

- Rhopilema Esculenta (BizenKurage, left)
- Rhopilema Hispidum (Hizen Kurage, middle)
- Nemopilima Nomurai (Echizen Kurage, right)



However, Rhopilema Esculenta is the most commonly consumed specie and the other two are regarded as substitute and the value is much lower.

Jellyfish is processed in Japan but the production volume was not found. In addition there is quite a large volume of import from Thailand, Indonesia, China, etc. Japan does not export jellyfish products.

Total import: (2007) 5110 M/ton ~ JPY 2225 million
 (2008) 6779 M/ton ~ JPY 2907 million

According to Marutomo's Web site, it distributes 1300 Tons of jellyfish products with the market share of 40.4%. Other producers are Maruta Food (10.8%), Kanetoku (10.2%), Marine Foods (9.4%), Takeda Food (8.1%).

In addition to consumption as food, there have been intensive research on the health effect of Jellyfish by Ehime University and Marutomo Co, Ltd. have made a soil conditioner from Jellyfish that can be a help to greening desert:



Fukui Prefectural Univ have been doing some research in the field of

- Extraction of Collagen from Echizen Jellyfish
- Production of Lectin from Echizen Jellyfish

Another study on Collagen extraction have been made by Toshiba – in relation to Power plant. Marutomo Co., Ltd, the largest importer & distributor of Jellyfish products (as food) in Japan are conducting research on health aspects of jellyfish together with Ehime University and is selling jellyfish collagen supplement extracted from jellyfish and bath salt with jellyfish collagen.



A college in Obama have found ways to create a powder from the Nomura jellyfish, and have made cookies and sweets based on the powder.



3.11 China

China has long tradition in utilizing jellyfish as food, both for ceremonial purposes and for its documented health effects. 2 species of jellyfish have been targeted for destruction by Chinese government:

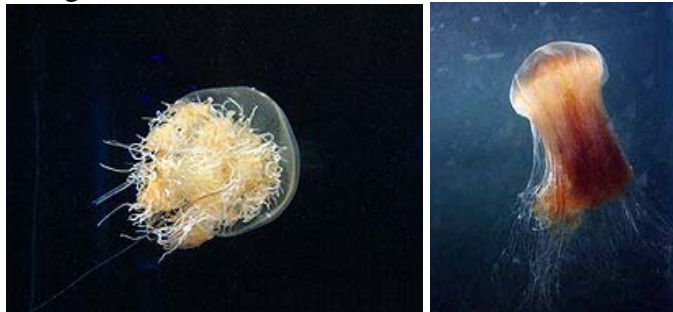

Nemopilema nomurai

Cyanea nozakii

Nemopilema nomurai

Growing up to 2 meters (6 feet 7 inches) in diameter and weighing up to 220 kilograms (ca. 450 pounds), Nomura's Jellyfish reside primarily in the waters between China and Japan, primarily centralized in:

- 1) The Yellow Sea connecting to China, Korea and Japan and
- 2) East China Sea between China and Japan.

Cyanea nozakii one of 14 species under the Family of Cyaneidae. Although most of Genera (*Cyanea*, *Desmonema* and *Drymonema*) and species under this Family are commonly found in the southern part of the Atlantic Ocean, *Cyanea nozakii* under this family has historically been spread out twice in the East China Sea between China and Japan. It has been spread out in Dalian in 2007 as well.

As mentioned under the Korea section, there is a regional cooperation program among China, Japan and Korea to solve problems caused by jellyfish. It is a government financed and coordinated program. Each country has set up a 'jellyfish team'. Based on this cooperation program, series national and regional activities have been implemented on two directions of both destructing low value species and utilizing commercial valuable species. This cooperation program has been initialized since 2005. In China, Fisheries Bureau of Ministry of Agriculture is the organizer and coordinator. The East Fisheries Research Institute of China Fisheries Academy of Science is mainly carry out this work in China. Researcher from Liaoning Provincial fisheries research academy is joining this work.

Potential customers for destruction of jellyfish as a service can include:

1. Electricity power plants along coastline are relevant potential customers that definitely need and able to afford COJECT. For instance the power plant, in Qingdao city, had a serious accident caused by swarms of jellyfish clogged seawater intakes and water recycling filter system in July 2009. They use workers and shovels to clean it.
2. Coastal tourism resorts could be potential customers as well. This business sector has being plagued by swarms of jellyfish every year in most famous tourism coastal cities in China. However, local governmental organization might be the buyer for COJECT.
3. Fishing vessels do need COJECT but most fishermen/fishing vessels are NOT really willing to pay for doing it, because
 - 1) many fishermen are not able to afford it,
 - 2) Individual fishing vessel use it don't work to solve swarms of jellyfish in the whole fishing ground, and
 - 3) fishermen hope government pay for the bill.

As a food resource, several types of jellyfish are used in China and exported to other countries. 8-10 jellyfish species are commonly found along Chinese seashore. *Rhopilema Esculentum* Kishinouye is the main species for food, taking more than 80% of all jellyfish production used for culinary uses. This species is larger and more rigid bodies and its toxins are harmless to humans compare to others.

Price/Pricing

Prices are very different in large range dependent on species, raw/whole, processed, recipe, skin or head, quality and packing, etc. For raw/whole and salted already, it is around RMB 1-2 per kg. For processed products, it could be RMB 8-100 per kg. (1 NOK is around 1.1150 RMB in September 2009)

Prices in many wholesale markets or local wet markets are generally low. But some high quality/price products are also sold through this channel. The prices in supermarkets, such as in Carrefour Beijing, have similar quality/price products compare to wholesale/wet markets. Small and nice packing, 60/250 grams, ready-to-eat and seasoning products are around RMB 3-10 per package. Some products prepared for exporting to other Asian markets could be around RMB 50-100 per kg.

Jellyfish wholesale price in different wholesale markets in China						
2009-11-17 2009-11-16 2009-11-15 2009-11-14 2009-11-13 2009-11-12 2009-11-11						
						Unit: RMB/KG
						Date of offer: 2009-11-17
Product	Market	Specification	High price	Low price	Average price	Price trend
Skin	苏州市南环桥市场发展有限公司	Frozen	16.00	12.00	14.00	
Skin	江苏省吕四港水产品批发市场	R. esculentum Kishinouye (海蜇)	0.00	0.00	94.00	
Skin	天津市南开区王顶堤水产批发市场	R. esculentum Kishinouye (海蜇)	0.00	0.00	15.00	
Skin	上海市钢川水产批发市场	R. hispidum Vanhoffen (黄斑海蜇)	0.00	0.00	36.00	
Skin	浙江省瑞安水产城有限公司	R. esculentum Kishinouye (海蜇)	0.00	0.00	56.00	

Processing

Traditional processing methods, carried out by a Jellyfish Master, involve a 20 to 40 day multiphase (normally 3 phases) procedure in which after removing the gonads and mucous membranes, the umbrella and oral arms are treated with a mixture of table salt and alum, and compressed. Processing reduces liquidation, off-odours and the growth of spoilage organisms, and makes the jellyfish drier and more acidic, producing a "crunchy and crispy texture." Jellyfish prepared this way retain 7-10% of their original weight, and the processed product contains approximately 94% water and 6% protein. Freshly processed jellyfish has a white, creamy colour and turns yellow or brown during prolonged storage.

Notes on the processing of jellyfish:

- Chinese national standard (GB) for processing jellyfish is available in Chinese edition only.
- The maximum percentage of alum is 1.2-2.2%.
- Borax and boric acid are strictly forbidden.
- Industrial salt is strictly forbidden.
- Detailed processing methods are available in Chinese edition only. And different companies have their own special methods/recipes. (We can translate it but need more hour resources.)
- Many professional processing companies are mainly based in north China coastal areas, except few in south China coast as well.

The ways to prepare jellyfish food simple:

- Desalted by soaking in water overnight and eaten cooked or raw.
- The dish is often served shredded with a dressing of sesame oil, garlic, chili sauce, soysauce, vinegar and sugar.
- As a salad with vegetables.
- Today, many brands of ready-to-eat (RTU) seasoning products are available used as appetizer.

Processing cost

The processing cost is always vague depended on what kind of product and its quality, how many factors are put into calculation. A rough cost estimation as below is based on jellyfish processing company.

- RMB 0.1-0.4 for per kg raw/whole salted
- For further processed products, processing cost takes around 10-15% of the sales price.

However, many processing private units/companies weight labour cost extremely low. Many jellyfish farmers even don't calculate theirs own labour cost although they handle a lot of heavy work during the first step of processing.

Market

China is a matured market for jellyfish as food with long history. Jellyfish food is popular not only in coastal areas but also all inland areas in whole China including both city and countryside market. It is sold in all kind of markets – local wet market, wholesale market, supermarket, chain store, etc. And it is available in most restaurants from extremely cheap one to the top luxury restaurant.

Many processed ready for eating jellyfish products are exported to many countries, and it is increasing.

A large variety of processed products with big price difference give consumers more free choices. The present jellyfish production is not enough to meet food market demand. The production of local fishing jellyfish is not stable and not enough. Sea ranching/enhancement, farming and imported jellyfish are substitutes.

Means of acquiring jellyfish for consumption:

Coastal Fishing

- Species: *Rhopilema esculentum* Kishinouye (海蜇)
- Production: Around 224,000 tons in 2007. It's not stable resource. Before 1980s, Zhejiang province used to be the main fishing production area. Today, Liaoning province is the main fishing production area. Refer to following table.
- Fishing areas: Mostly in north China and some in south as well.
- Fishing method: Small trawl

Aquaculture

- Species: *Rhopilema esculentum* Kishinouye (海蜇) in north China and *R.hispidum* Vanhoffen in south China.
- Production: Around 40,000 tons (processed) in 2007. It's keep increasing steady and gradually dependent on local and Asian market demand for food products.
- Farming areas: Mostly in north China and some in south as well.
- Farming method: Poly-aquaculture in shrimp farming ponds is getting popular.
- Aquaculture company: For instance, Homey Group

Sea ranching/enhancement

- Species: *R. esculentum* Kishinouye (海蜇)
- Quantity: Various year by year and province by province. For instance, around 20 million released into East China Sea (33°50.511 N, 120°34.811 E~33°50.405

N, 120°37.439 E in May 2009; 250 million released into BoHai Sea in north China in June 2007.

- Areas: Mostly in north China and some in south as well.
- Organizer/coordinator: Fisheries authority in Ministry of Agriculture, coastal provincial fisheries authorities and research organizations in China.

According to China ministry of commerce and Chinese food safety authority, Yingkou city in Liaoning province is the biggest jellyfish processing and export base in China, exported around 2,000 tons in 2007. It almost takes 50% of total exported jellyfish production from China.

Amino Acid and collagen products R&D and application

The First Research Institute of the State Oceanic Administration is holding a patent technology of extracting collagen from jellyfish. This technology is developed and patent by this institute. So far, this patent is still not applied in commercial business yet. This research institute uses *R. esculentum* Kishinouye to produce collagen product. However, it is not clear if this institute is able to extract collagen from other jellyfish species. So far, we did not identify any company in China starting commercial business producing collagen by jellyfish.

Jellyfish as feed resource for aquaculture

In northeast Asia, *Nemopilema Nomurai* is the species caused problems to other economical businesses. R&D organizations and governmental authorities have put effort trying to use this species producing feed for fish, shellfish and crab. In Japan, both R&D and trial business have been kicked off to develop snow crab feed from *Nemopilema Nomurai*. In China, the species, *R. esculentum* Kishinouye, is not enough for producing food products. Some researchers are studying to develop *Nemopilema Nomurai* into fish feed. But this R&D work is slow and no obvious breakthrough happened so far because of various reasons, such as too much work, low output, taking time, uncertain price, seashore and coastal water environment concern, etc.

Other R&D activities on jellyfish

Homey Group together with the Biology Research Institute of Shandong provincial Academy of Sciences have developed a nutrition liquid/health drink from jellyfish. This technology and product have gotten patent in May 2009. Homey Group has established an international commercial project in August 2009. Foreign companies are invited.

China Ocean University are studying Chinese traditional medicine use jellyfish raw material, i.e. *R. hispidum* Vanhoffen, as one content of prescription for treating diseases of gout, arthritis, tracheitis, high blood pressure, scrofula, asthma, etc. Today, jellyfish collagen can take over its raw material.

Ningbo University are conducting R&D on extracting jellyfish venom (toxin) and its pharmaceutical function study. And Department of Food Chemistry and Nutrition of College of Food Science and Engineering in China Ocean University are working on antioxidant and melanogenesis-inhibitory activities of collagen peptide from jellyfish.

3.12 Europe

Europe's focus on jellyfish is in regards to the increasing problems the jellyfish swarms cause to the tourism. Especially Spain, Italy and France have reported infestations and in some cases

there have been reports on countermeasures (nets and barriers) and actions taken to reduce the threat to the countries' tourists. There are however no evidence to dealing with the source of the problem and battling jellyfish in the open seas. For the time being, jellyfish is not being utilized in any way in Europe, except on a very small scale level in research etc.

3.13 Africa

Even though it has been widely recognized that the jellyfish invasions off the coast of western Africa is a problem, there seems to be very little activity in regards of countering the problem. Main research projects are focusing on understanding the behaviour and environmental aspects of the jellyfish and the reasons for the invasions. MMI has not been able to find any evidence that the jellyfish represent a threat to the tourism on the African coast, however this might be related to the absence of information in general from Africa.

7. Areas of application

There seems to be two distinct areas of application with one of them leading to several possibilities: The destruction of jellyfish as a service, and harvesting jellyfish as a resource.

3.14 Destruction of jellyfish

Destruction of jellyfish as a service to remove jellyfish and enhance other marine life is dependant on somebody willing to pay for such a service.

3.15 Harvesting jellyfish for processing

1. Human consumption
2. Fish feed
3. Collagen
4. Other applications

8. Technical/commercial handshake

In order to be able to make decisions on the way forward for COJECT, one need to look at the existing technology and identify the status and need for further development together with key operators. For the time being, COJECT has an operational pilot destruction unit and a model of a selective trawl. The other technologies in COJECT is undeveloped or at a conceptual stage. In the following we will briefly look at what needs to be done with the existing technology in order to comply with the areas of application and what players (identified where applicable) are involved;

1. Destruction
2. Consumption

- 3. Collagen (fish feed, medical/chemical/pharmaceutical)
- 4. Other

Destruction / Service

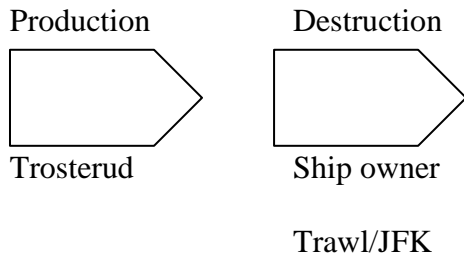

- Destruction unit need to be further developed
- Trawl need to developed
- Education of crew
- Egg-destructor/detoxifyer need to be developed

In addition to trawl, both Korea and China have reported problems related to the sea water cooling intakes of (nuclear) power plants. A business opportunity might arise from manufacturing protective devices for such plants.

Fishing for consumption (food)

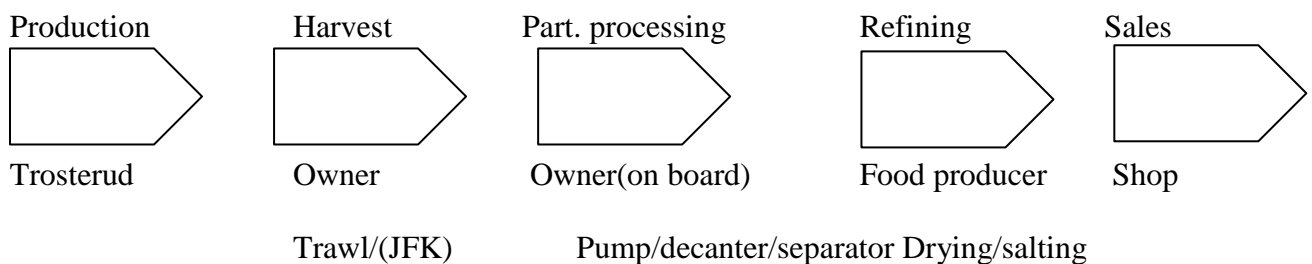

- Jellyfish as food might require uncut jellyfish (mesoglea) brought on board. (no destruction unit)
- Method for bringing jellyfish (unharmed?) onboard
- Pre processing on board of vessel need newly developed equipment, and require certain types of fishing vessels (suitable cargo hold etc)
- Refining of jellyfish on shore, or onboard depending on time aspect

Fishing for fish feed/collagen

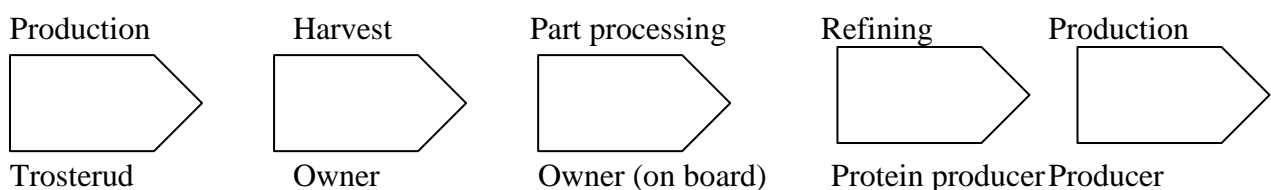

Producers will be fish feed producers or chemical/pharmaceutical industry.

- Method for bringing jellyfish on board need to be developed
- Preprocessing method onboard (mainly extraction of water) need to be developed, or bought from NFRDI that has developed a device that eliminates water from jelly fish
- Method for extracting collagen are patented and need to be assessed
- Use of substitute in fish feed depends on quality of collagen (picky fish) and that the jellyfish protein is stable and available in large quantities
- Research and evaluate the amino acid profile of jellyfish protein

Other applications such as fertilizer and cookies relies on various forms of refining after the jellyfish is harvested, but are similar to the abovementioned value chains. Market development for such products need to be assessed as well.

Removal of water from jellyfish

In order to harvest jellyfish a large amount of water need to be removed from the jellyfish at an early stage, as transporting “water” is not economical. Due to the osmotic nature of jellyfish (same mass as water), separator or centrifuges will be less efficient. Decanters on the other hand could remove the unwanted water from the jellyfish. A typical large (5x2x1,5 m) decanter has a capacity of 70-100 m³/h with an energy consumption of ~90-140 kW, so several decanters would be needed to process ~250 m³/h jellyfish catch. The price of a decanter with the needed capacity is 700k-1 million dollar and weights about 10-15 tonnes.

Such a decanter, working 24h a day would produce jellyfish matter with 5% water at a rate of 3-5 tonnes/h. As an example a 650 m³ wellboat (Ronja L=40 m, beam 10 m, depth 4,6m) would be filled in 130-200 hours (5-8 days) using only one decanter. The day rate for such a vessel in Norway is approx 8000\$.

Fuel costs are estimated to 13-15\$/h pr decanter, giving ~2000\$ pr fully loaded boat. The approximate value of jellyfish collagen in a fully loaded boat, will vary based on the sale price of the refined product. Given the price of 10\$/kg, a fully loaded vessel can deliver source jellyfish material (12-24 tonnes (2-4%)) that can give revenues 120-240.000\$ for refined product. However, several articles referred in this paper gives the amount of collagen to less than 1%, and the raw product can not be sold for 10\$/kg. If a parallel is drawn to fish skin collagen, 25-50 tonnes of fish skin/bone is needed to produce 12-24 tonnes of collagen, at a cost of 2500-5000\$ for the skin/bones. The value of a boatload of jellyfish matter is therefore closer to 5000\$ in value than 100.000 \$.



In total, given no other financial costs than fuel to decanters and day rate of the boat, a boatload of jellyfish would have expenses that exceed the income ~ 50.000 \$ (based on 6 days of operation).

9. IPR

3.16 Background

To process jelly fish, COJECT has been investigating the use of a technology developed by Børre Høver and described in the unpublished patent application NO20072921, the Coject technology. Leogriff, as an independent advisor in the field of intellectual property strategy, has been asked to give a brief opinion on the current patentability of this technology.

3.17 Summary

As a result of a relatively brief patent prior art search, it is our opinion that the Coject technology, limited to a hydraulically-driven shredder at the end of trawl net provided with counter-rotating chopping blades, is patentable. In addition, this brief work invites us to believe that the Coject technology would have good chances not to meet any major Freedom To Operate challenge.

3.18 The Coject technology described in NO20072921

NO20072921 describes a processor to be adapted at the end of a trawl net, and made of counter rotating disks equipped with chopping blades, and energised thanks to sailing of the trawler.

In its office action, Patentstyret cited two patents, summarised in our digest below, and opposed the application on the basis that it would not work. Later opinions by experts in the field (opinion by Ole Dahlhaug, 1.Amanuensis at the Vannkraftlaboratoriet at NTNU, and investigations by Mikro & Minikraft AS) do on the contrary support the invention in that it should work.

Note that the prior art was cited against a rather broad first claim, an apparatus to collect and process (kill and shred) jelly fish thanks to a turbine-driven mill.
Interesting patents

3.19 Cited Patentstyret patents

JP02008409 to Yoshinao

This patent application discloses a hydraulically driven jelly fish mill, to apparently be trawled in the sea. This patent is a relevant prior art in terms of concept of a trawled hydraulically driven “jelly fish” cleaner, but only discloses a relatively simple milling solution, which engineering is not the purpose of the application.

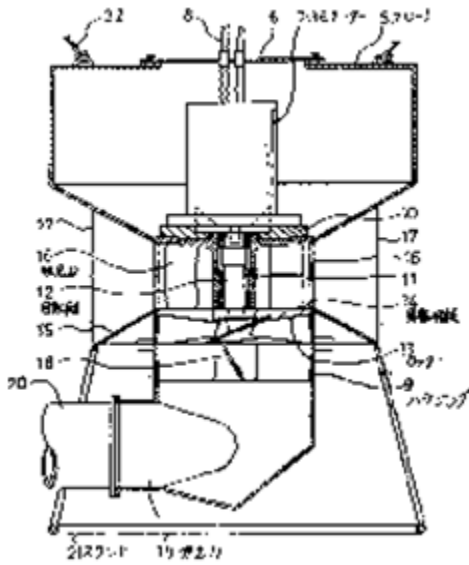

JP2002000125 to Yatabe

This application discloses an electrical motor driven helicoidal crusher, relevant in terms of the problem to solve, but not in terms of engineering. It seems at first sight to relate to a device fixed to the ship, not a trawl-type solution.

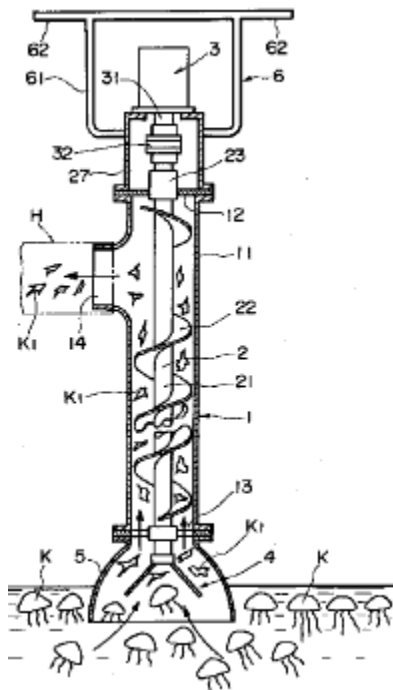

3.20 Other interesting prior art

The most relevant patents and patent applications found were from Korea and Japan, and in the form of English abstracts.

KR2009062020A to Joowoonenc

This application discloses a hydraulically-driven chopper, relevant in terms of the problem to solve and the source of chopping energy, but not in terms of detail engineering.

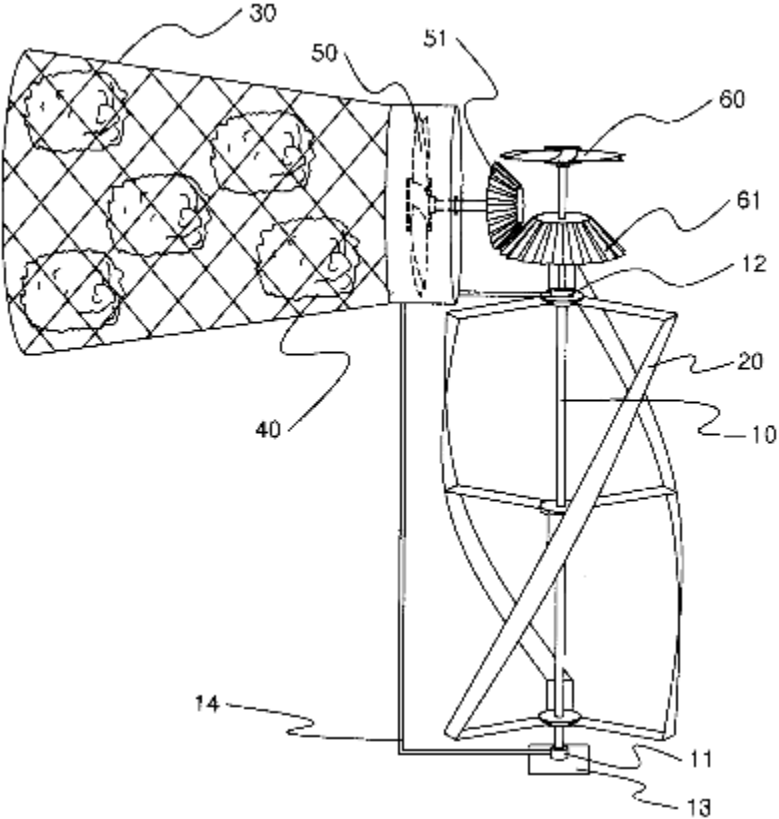

KR2008034744 to Kim

This application discloses a jelly fish chopper, relevant in terms of the problem to solve, but not in terms of general engineering.

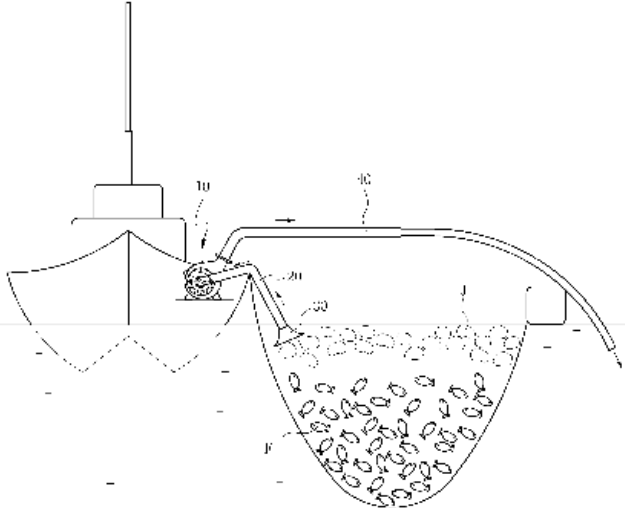

Other patent/application relevant to the problem to solve but not the engineering were KR683571 and JP2008167707.

3.21 Discussion

Whereas cited and found prior art do clearly disclose hydraulically-driven trawled jelly fish chopping devices, none invites to engineer the chopping mechanism as in the Coject technology.

It is our opinion that the Coject chopper is new, and inventive over the prior art and current know-how in the related fishing industry. The preliminary negative position of the Patentstyret regarding the workability of the invention signals a clear inventiveness.

However, the claim set will need to focus on the core of the invention, i.e. not the concept of chopping jelly fish collected at the end of a trawl net, but a hydraulically-driven shredder provided with counter-rotating chopping blades at the end of a trawl net.

This brief work focused on patentability cannot be the base of a Freedom To Operate analysis. However, in view of the analysed prior art, we believe that the Coject technology would have good chances not to meet any major Freedom To Operate challenge.

Please note that our opinion needs to be taken into account at the light of two uncertainties:

1. the prior art search has been rather brief, and even a very exhaustive search cannot claim having detected all relevant prior art,
2. the opinion of a patent authority examiner cannot be foreseen with certainty.

3.22 Methodology and searches

The filed patent application, Patentstyret office action (“uttalelse”) and cited prior art, further development report, as well as a brief additional search have been analysed. Prior published filing by the same inventor (NO 20065121) has also been checked for disclosing information.

10. Funding

It seems evident that COJECT need more funding in order to complement and further develop the jellyfish system. Several key units are not developed or are at very early stages in development. Relating to gain funding to the further development of COJECT we have reviewed the following possibilities:

1. Private investor
2. Norwegian grants and governmental programmes
3. FAO

Private investors

In order to attract private investors COJECT need to show a positional market that can give private investors return on investment. Possible investors are likely found in markets that can utilize jellyfish in some way, either directly or as a part of another product they produce. Fish feed producers and pharmaceutical industries are two possibilities. However there seems to be significant risk associated with developing jellyfish products and in some areas (like destruction of jellyfish in Asia) there are high entry barriers. None of the Norwegian farm companies and fish feed producers have replied positively when confronted with the opportunities.

Norwegian grants and governmental programmes

Innovation Norway (IN) represents such financial instrument that is willing to take a higher risk than private investors. However IN can not fund a project/programme 100%, and a partner is probably needed to meet the requirements for funding. Funding by IN depends on COJECTS ability to find a partner that can take 40-60% of the funding.

NORAD is a governmental aid body that engages in developing aid programmes especially in the third world. They state that global climate change and loss of biodiversity are among the most serious environmental threats to the world at present. However they act through local programmes in developing nations, very much in the same way IFAD does:

- aims to be the centre of expertise for evaluation, quality assurance and dissemination of the results of Norwegian development cooperation, jointly with partners in Norway, developing countries and the international community
- will ensure that the goals of Norway's development policy are achieved by providing advice and support to the Ministry of Foreign Affairs and Norwegian foreign service missions
- will administer the agency's grant schemes so that development assistance provided through Norwegian and international partners contributes effectively to poverty reduction

Direct funding from NORAD seems not plausible unless COJECT is part of a larger development program in a region.

FAO

FAO is not a donor organization. FAO is one of three UN food agencies based in Rome. Each of these organizations has different goals. By working together and sharing their expertise each one helps the other do a better job at reducing poverty and hunger around the world.

IFAD

However FOA collaborates with other UN organizations that are directly involved in funding. International Fund for Agricultural Development (IFAD) "Fund" is the key word here. IFAD operates as a kind bank. Unlike FAO, which is not a funding agency, IFAD specializes in financing rural development projects. IFAD projects are designed to help improve the nutritional level and living conditions of the poorest populations in developing countries. IFAD and FAO collaborate on many projects.

IFAD Core principles

Drawing on the success of past investments in multi-location, international agricultural research, IFAD's strategy is to support initiatives in adaptive research and related capacity building. This global and regional research strategy is based on three related core principles:

- The local institutional and technological problems faced by poor rural people in marginal, resource-poor areas are similar, although local specificities are distinct. They can best be addressed through multi-location research with a community participatory approach and through sharing knowledge across the sites.
- Many poverty-relevant research and development (R&D) issues require human and capital resource mobilization beyond the capacity of local and national organizations.

For example, networks of national research systems linked to international agricultural research centres have proved to be better equipped and generally more effective in addressing a common set of problems.

- Cross-country and cross-regional learning is essential to reap the benefits of replicable practical innovations, building on the rich diversity of local knowledge and practices in rural communities.

In recognition of this potential, IFAD's grant portfolio continues to support the development of innovative R&D approaches to issues affecting poor rural people. Such approaches are increasingly relevant in the context of national poverty reduction strategies and in efforts to harness science and technology for the purpose of realizing them.

IFAD grant policy

The [Policy on Grant Financing](#), updated in [September 2005](#), included new strategic objectives, allocation modalities and implementation procedures.

The Policy stipulates that:

- grants should focus on interventions where they have a significant *comparative advantage* over loans as a financing instrument
- grants should *complement* the loan programme.

The policy includes two strategic objectives, representing priority areas for IFAD's regular grant resources:

- promoting pro-poor research on innovative community-based approaches and technological options to enhance field-level impact; and /or
- building pro-poor capacities of partner institutions, including community-based organizations and NGOs.

Debt sustainability framework

IFAD uses the DSF to decide the form of the organization's financial assistance to countries eligible for highly concessional lending. To assess the debt status of a given country, IFAD uses the classification of countries in terms of debt sustainability that is produced by the World Bank and the International Monetary Fund in their country debt sustainability analyses. On this basis IFAD extends financial support to programmes and projects governed by the performance-based allocation system (PBAS) in countries eligible for highly concessional loans. The organization extends support on the following basis, in line with the International Development Agency (IDA) and the African Development Fund (ADF):

- countries with low debt sustainability: 100 per cent grant
- countries with medium debt sustainability: 50 per cent grant and 50 per cent loan
- countries with high debt sustainability: 100 per cent loan

IFAD works on a governmental level, ie programmes initiated by local government or in some cases local NGOs. In order to be eligible for funding (if any) projects must comply with the

abovementioned requirements and initiated by a local government. By scanning the grants/funding given by IFAD the focus of the organization is development in extremely poor regions of the world. By request they have not been able to give any clear answers to whether COJECT could be in position to receive funding. They did however emphasize the core activity as supplementing development activities in poor rural areas in the agricultural sector.

11. Conclusions and summary

Technical

The COJECT has developed and tested a prototype destruction unit for jellyfish, however other parts of COJECT are either on the prototype/model stage or earlier stages. Further comprehensive development is needed to bring the system to the market, especially on the trawl and detoxification units. It seems evident that some form of pre-processing is needed onboard which also needs to be developed. It is assumed that considerable funds are needed, and that COJECT probably needs to find a partner that is willing and committed to fund the further development of COJECT as the project group itself does not have the available resources. There exist some technology in regards to collagen extraction and pre processing that can solve some of the technical challenges COJECT faces, but no technology in regards to egg destruction and detoxification have been identified.

Market

In the **Asian** market (China, Japan and Korea) the following findings can be seen as a representation for the market possibilities for destruction of jellyfish:

1. There is a regional cooperation programme on jellyfish in northeast Asia, coordinated by government and carried out by research organizations in Japan, Korea and China at national level. Activities under this program include both destruction and utilization of jellyfish. This program is looking for international cooperation in principle. However,
2. Based on this program, Korea and Japan has been developing jellyfish eliminating technologies and products mainly for fishing industry. If COJECT could be in position to receive funding from such an initiative, or if the COJECT could be a supplier of technology to such programme will depend on if COJECT is advanced/better than Korean and Japanese.
3. Other industrial sectors, such as power plant and tourism, have no regional or national program for eliminating jellyfish swarms. But there might be business possibility for COJECT technology/product.
4. *Nemopilema nomurai* is the main species that caused big trouble to other coastal industries. (Note: The cooperation program will publish a book including all jellyfish species around this region.)

If the scope is widened to include a possible refining or harvesting of jellyfish as a resource, in Asia the following conclusions can be drawn:

1. Jellyfish as food is a tradition and well developed in China. *Rhopilema esculentum* Kishinouye is the main species, taking more than 80% of total jellyfish production for culinary uses. Price of raw/whole and salted is low. Processing gives the consumer a large

variety choice in a large range of price. Market for jellyfish is big and continuous increasing. Coastal jellyfish fishing production can not meet food market demand. Jellyfish farming, sea enhancement and importing are on-going as well. Processed jellyfish products have been exported to many countries especially in Asia. Japan and Korea are using jellyfish as food as well although it is not a strong tradition compared to China. In recent years, more and more attentions and R&D efforts to develop jellyfish food products have been taken place while solving jellyfish caused problems.

2. Amino acids only few research articles but no business information about market players and business for deriving amino acids from jellyfish in this region.

3. Collagen There exist R&D activities on developing nutrition/health products based on both R&D organizations and companies in this region. Some research organizations and companies have been mentioned, but the commercialization has not been well proved yet. Japanese and Korean cosmetic companies are leading group.

4. Feed additives R&D and application for feed is not really started yet, except few research articles.

5. Other R&D and applications

- a) Cosmetic and food & beverage additives R&D and applications in Korea;
- b) Soil conditioner and cosmetic R&D and application in Japan;
- c) R&D and commercial production of nutrition liquid/health drink, Chinese traditional medicine application, R&D on extracting jellyfish venom (toxin) and its pharmaceutical.

Africa

Even though it has been widely recognized that the jellyfish invasions off the coast of western Africa is a problem, there seems to be very little activity in regards of countering the problem. Main research projects are focusing on understanding the behaviour and environmental aspects of the jellyfish and the reasons for the invasions. MMI has not been able to find any evidence that the jellyfish represent a threat to the tourism on the African coast, however this might be related to the absence of information in general from Africa.

Europe

Europe's focus on jellyfish is in regards to the increasing problems the jellyfish swarms cause to the tourism. Especially Spain, Italy and France have reported infestations and in some cases there have been reports on countermeasures (nets and barriers) and actions taken to reduce the threat to the countries' tourists. There are however no evidence to dealing with the source of the problem and battling jellyfish in the open seas. For the time being, jellyfish is not being utilized in any way in Europe.

Fishfeed:

- Amino acids need to be mapped, nutrition value
- Protein source worldwide is available in large quantities
- 1 ton of protein equals 1000 tons raw jellyfish
- Price of traditional protein resource (65% proof) is 700-1500 \$/ton ~10.000 NOK pr ton (100% proof)
- Unknown if fish/marine creatures will eat it
- NFRDI claims that minced jelly fish could become an effective feed for younger fish at fish farm site, and Chinese are researching feed for snow crabs.

Based on this does it not seem plausible to commercially catch jellyfish for its protein (collagen) exclusively. (cod price ~12.000 NOK pr ton)

Consumption:

- Certain jellyfish are more valuable than others, for example Nomura jellyfish is not widely used because of taste
- Jellyfish need to be treated gently, making the harvesting more complex
- Time-consuming processing requires low cost labour or new technology
- Market is located mainly in Asia

Collagen:

- 1 ton of protein equals 1000 tons raw jellyfish
- Price of refined consumable collagen is: 10-20 \$/kg
- Method of extracting collagen (IPR) is owned by others
- Quality of collagen determines application area and price
- In total, given no other financial costs than fuel to decanters and day rate of the boat, a boatload of jellyfish would have expenses that exceed the income ~ 50.000 \$ (based on 6 days of operation).

Destruction

- Unwillingness to pay for service as jellyfish drift around and are not place bound
- Estimates of fisheries enhancement needs to be verified
- Uncertain income model
- Local tourism enhancing bodies might be interested

IPR

- As a result of a relatively brief patent prior art search, it is our opinion that the Coject technology, limited to a hydraulically-driven shredder at the end of trawl net provided with counter-rotating chopping blades, is patentable. In addition, this brief work invites us to believe that the Coject technology would have good chances not to meet any major Freedom To Operate challenge.

Funding

- Private investors need to see the potential, no interest identified among Norwegian players
- Global Soft funding (NORAD, IFAD (FAO)) is possible, but probably need local governmental projects.
- Local soft funding (joint programmes in Asia etc) do not generally block foreign initiatives, but might need to be proven better than local initiatives (Japan etc)

Based on the abovementioned items it doesn't seem plausible to harvest and process jellyfish for its valuable dry matter (collagen). The process of harvesting and process such huge amounts of jellyfish to produce 1/1000 parts collagen, will demand too much energy and time to produce a product (depending on quality) in the range of 1000\$/ton. Further refining is possible, but at the moment not scalable, and the quality of the end product is hard to define.

Destruction of jellyfish as fishery enhancement has no clear return of investment, and it seems unlikely that it will attract private funding, leaving governmental and organisational funding. As identified such funding is generally given through local projects and organisations, often in partnership with a NGO or UN body. However such projects and funding leaves COJECT with a highly uncertain potential income, depending on business model. Joint venture with a research body, such as Havforskningsintitutet or similar organisations mi

NEA - Seoul, Tokyo and Beijing

Jellyfish Market Scan – Japan, Korea and China

Summary

Destruction of jellyfish

1. There is a regional cooperation programme on jellyfish in northeast Asia, coorganized by government and carried out by research organizations in Japan, Korea and China at national level. Activities under this program include both destruction and utilization of jellyfish. This program is looking for international cooperation in principle. However,
2. Based on this program, Korea and Japan has been developing jellyfish eliminating technologies and products mainly for fishing industry. If COJECT could be in position to receive funding from such an initiative, or if the COJECT could be a supplier of technology to such programme will depend on if COJECT is advanced/better than Korean and Japanese.
3. Other industrial sectors, such as power plant and tourism, have no regional or national program for eliminating jellyfish swarms. But there might be business possibility for COJECT technology/product.
4. *Nemopilema nomurai* is the main species that caused big trouble to other coastal industries. (Note: The cooperation program will publish a book including all jellyfish species around this region.)

NEA - Seoul, Tokyo and Beijing

Jellyfish as a commodity/resource

1. *Jellyfish as food* is a tradition and well developed in China. *Rhopilema esculentum* *Kishinouye* is the main species, taking more than 80% of total jellyfish production for culinary uses. Price of raw/whole and salted is low. Processing keep developing gives consumer a large variety choice in a large range of price. Market for jellyfish is big and continuous increasing. Coastal jellyfish fishing production can not meet food market demand. Jellyfish farming, sea enhancement and importing are on-going as well. Processed jellyfish products have been exporting many other countries especially in Asia. Japan and Korea are using jellyfish as food as well although it is not tradition. In recent years, more and more attentions and R&D efforts to develop jellyfish food products have been taken place while solving jellyfish caused problems.
2. *Amino acids* only few research articles but no business information about market players and business for deriving amino acids from jellyfish in this region.
3. *Collagen* There are mainly R&D activities on developing nutrition/health products based on both R&D organizations and companies in this region. Some research organizations and companies are mentioned in each country report. But the commercialization has not been well proved yet. Japanese and Korean cosmetic companies are leading group.
4. *Feed additives* R&D and application for feed is not really started yet, except few research articles.
5. *Other R&D and applications*
 - Cosmetic and food & beverage additives R&D and applications in Korea;

- Soil conditioner and cosmetic R&D and application in Japan;
- R&D and commercial production of nutrition liquid/health drink, Chinese traditional medicine application, R&D on extracting jellyfish venom (toxin) and its pharmaceutical function study in China;